

*Parting and  
grooving tools*





# TURNING Parting and grooving tools

How to select parting and grooving tools

## How to select parting and grooving tools

### Structure of parting and grooving tools selection table

- Categorized as external machining, internal machining and profile machining.
- Concluded and separately listed according to product series (Little squirrel series and Supplementary series).

Dimensions

Application of external machining, internal machining and profile machining

#### External parting, grooving and turning tools

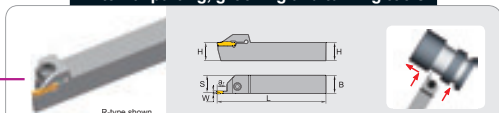

Type	Stock		Basic dimensions(mm)						Applicable inserts	Screw	Wrench	
	R	L	H	X	B	L	S	W				Br min
QEAD	1212RL07	▲	▲	12	12	125	11.4	1.5	7	ZCAD91500	GB70-85-M4 × 12	WH30L
	1212RL12	▲	▲	12	12	125	11.4	1.5	12	ZCAD91500	GB70-85-M4 × 12	WH30L
	1616RL07	▲	▲	16	16	125	15.4	1.5	7	ZCAD91500	GB70-85-M5 × 16	WH40L
	1616RL12	▲	▲	16	16	125	15.4	1.5	12	ZCAD91500	GB70-85-M5 × 16	WH40L
	2020RL07	▲	▲	20	20	125	19.4	1.5	7	ZCAD91500	GB70-85-M5 × 16	WH40L
QEBD	1212RL12	▲	▲	12	12	125	11.2	2	7	ZCB02000	GB70-85-M4 × 12	WH30L
	1212RL10	▲	▲	12	12	125	11.2	2	10	ZCB02000	GB70-85-M4 × 12	WH30L
	1212RL14	▲	▲	12	12	125	11.2	2	14	ZCB02000	GB70-85-M4 × 12	WH30L
	1616RL07	▲	▲	16	16	125	15.2	2	7	ZCB02000	GB70-85-M5 × 16	WH40L
	1616RL10	▲	▲	16	16	125	15.2	2	10	ZCB02000	GB70-85-M5 × 16	WH40L
	1616RL14	▲	▲	16	16	125	15.2	2	14	ZCB02000	GB70-85-M5 × 16	WH40L
	2020RL07	▲	▲	20	20	125	19.2	2	7	ZCB02000	GB70-85-M5 × 16	WH40L
	2020RL10	▲	▲	20	20	125	19.2	2	10	ZCB02000	GB70-85-M5 × 16	WH40L
	2020RL14	▲	▲	20	20	125	19.2	2	14	ZCB02000	GB70-85-M5 × 16	WH40L
	2020RL07	▲	▲	20	20	125	19.2	2	7	ZCB02000	GB70-85-M6 × 20	WH50L
QEED	1616RL10	▲	▲	16	16	125	15	2.5	10	ZJED02000	GB70-85-M5 × 20	WH40L
	1616RL17	▲	▲	16	16	125	15	2.5	17	ZJED02000	GB70-85-M5 × 20	WH40L
	2020RL10	▲	▲	20	20	125	19	2.5	10	ZJED02000	GB70-85-M6 × 20	WH50L
	2020RL17	▲	▲	20	20	125	19	2.5	17	ZJED02000	GB70-85-M6 × 20	WH50L
	2020RL10	▲	▲	20	20	125	19	2.5	10	ZJED02000	GB70-85-M6 × 20	WH50L
QEPD	1616RL10	▲	▲	16	16	125	14.8	3	10	ZJFD03000	GB70-85-M5 × 20	WH40L
	1616RL17	▲	▲	16	16	125	14.8	3	17	ZJFD03000	GB70-85-M5 × 20	WH40L
	2020RL10	▲	▲	20	20	125	18.8	3	10	ZJFD03000	GB70-85-M6 × 20	WH50L
	2020RL17	▲	▲	20	20	125	18.8	3	17	ZJFD03000	GB70-85-M6 × 20	WH50L
	2020RL10	▲	▲	20	20	125	18.8	3	10	ZJFD03000	GB70-85-M6 × 20	WH50L
QEGD	2020RL17	▲	▲	20	20	150	23.8	3	17	ZJFD03000	GB70-85-M6 × 20	WH50L
	2020RL13	▲	▲	20	20	140	18.5	4	22	ZJGD04000	GB70-85-M6 × 20	WH50L
	2020RL13	▲	▲	20	20	150	23.5	4	13	ZJGD04000	GB70-85-M6 × 20	WH50L

▲ Stock available △ Make-to-order

Specification of products Including type, basic dimensions, applicable inserts and accessories.

#### Internal grooving and turning tools

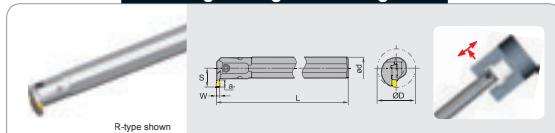

Type	Stock		Basic dimensions(mm)						Applicable inserts	Screw	Wrench
	R	L	ed	L	S	W	ar max	ØDmin			
C20Q-QEDR/L05-27	▲	▲	20	180	15.2	2.5	5	27	ZTED02600	GB70-85-M4 × 12	WH30L
C26R-QEDR/L07-33	▲	▲	25	200	20.3	2.5	7	33	ZRED02600	GB70-85-M5 × 16	WH40L
C32Q-QEDR/L09-42	▲	▲	32	250	25.3	2.5	9	42	ZRED02600	GB70-85-M5 × 16	WH40L
C20Q-QFDR/L05-27	▲	▲	20	180	15.2	3	5	27	ZTFD03000	GB70-85-M4 × 12	WH30L
C26R-QFDR/L07-33	▲	▲	25	200	20.3	3	7	33	ZTFD03000	GB70-85-M5 × 16	WH40L
C32S-QFDR/L09-42	▲	▲	32	250	25.3	3	9	42	ZTFD03000	GB70-85-M5 × 16	WH40L
C26R-QGDR/L08-35	▲	▲	25	200	21.5	4	8	35	ZTG00400	GB70-85-M5 × 16	WH40L
C32S-QGDR/L11-44	▲	▲	32	250	27.5	4	11	44	ZRG00400	GB70-85-M6 × 20	WH50L
C40T-QGDR/L13-54	▲	▲	40	300	33.5	4	13	54	ZRG00400	GB70-85-M6 × 20	WH50L
C26R-QHDR/L08-35	▲	▲	25	200	21.5	5	8	35	ZTHD05000	GB70-85-M5 × 16	WH40L
C32S-QHDR/L11-44	▲	▲	32	250	27.5	5	11	44	ZRH00500	GB70-85-M6 × 20	WH50L
C40T-QHDR/L13-54	▲	▲	40	300	33.5	5	13	54	ZRH00500	GB70-85-M6 × 20	WH50L
C26R-QKDR/L08-35	▲	▲	25	200	21.5	6	8	35	ZTKD06000	GB70-85-M5 × 16	WH40L
C32S-QKDR/L11-44	▲	▲	32	250	27.5	6	11	44	ZTKD06000	GB70-85-M6 × 20	WH50L
C40T-QKDR/L13-54	▲	▲	40	300	33.5	6	13	54	ZTKD06000	GB70-85-M6 × 20	WH50L

▲ Stock available △ Make-to-order

#### Profile turning tools for Al

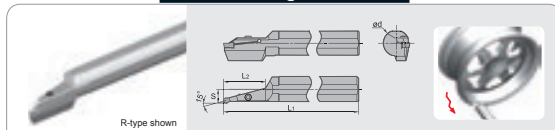

Type	Stock		Basic dimensions(mm)				Applicable inserts	Screw	Wrench	
	R	L	ed	S	L1	L2				
C40X-QLDR/L65-15A	▲	▲	160	40	21	320	65	ZRLD08-LH	GB70-85-M6 × 20	WH50L
C40X-QLDR/L80-15A	▲	▲	160	40	21	320	80	ZRLD08-LH	GB70-85-M6 × 20	WH50L
C40X-QKDR/L60-15A	▲	▲	160	40	20	320	60	ZRKK06-LH	GB70-85-M6 × 20	WH50L
C40X-QKDR/L75-15A	▲	▲	160	40	20	320	75	ZRKK06-LH	GB70-85-M6 × 20	WH50L

▲ Stock available △ Make-to-order

Indicating the minimum machining diameter The minimum machining diameter is very important for internal machining.



# TURNING



## Parting and grooving tools

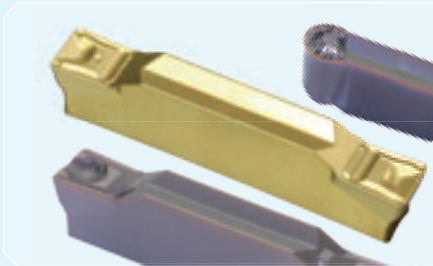
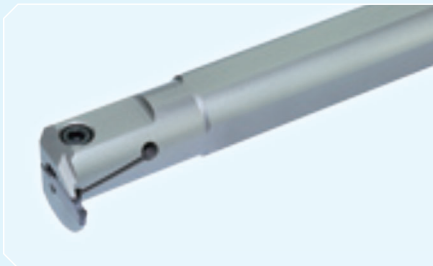

<b>Parting and grooving tools overview</b>	•	A250-A252
<b>Parting and grooving inserts</b>	•	A253-A269
Introduction of Little Squirrel series inserts chipbreaker	•	A254-A257
Parting, grooving and profiling inserts code key	•	A258
Inserts of Little Squirrel series	•	A259-A265
QC series shallow grooving inserts code key	•	A266
QC series shallow grooving inserts	•	A267-A268
Inserts of ZQMX series	•	A269
<b>Parting and grooving tools</b>	•	A270-A288
Little squirrel series	•	
Little squirrel series parting and grooving tools code key		A270-A271
External parting, grooving and turning tools		A272-A273
Precise grooving and turning tools		A274
External recess and profiling tools		A274
External grooving tools for materials hard to be machined		A275
External parting inserts and holder for external parting		A275
Surface grooving and turning tools		A276-A283
Internal grooving and turning tools		A284
Profile turning tools for Al		A284
<b>QC series shallow grooving tools</b>	•	
QC series shallow grooving tools code key		A285
External shallow grooving tools		A286
Internal shallow grooving tools		A286
<b>Supplementary series</b>	•	
Supplementary series parting and grooving tools code key		A287
QZQ external grooving series		A288
<b>Application information on parting and grooving</b>	•	A289-A290























# TURNING / Parting and grooving tools

## Parting and grooving tools overview

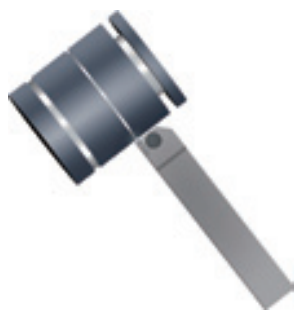









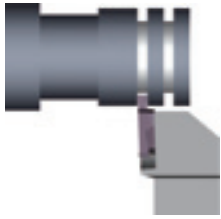

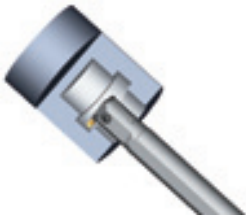



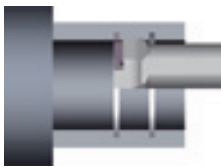

General turning  
Parting and grooving

Parting and grooving tools overview

Machining application	Machining type	Applicable tools	Corresponding inserts	Tool features and parameters	
External machining	Parting	<p>Little squirrel series QZ□□+QE□□</p>  <p>A275</p>	<p>Parting inserts ZP□S□□</p> 	<ul style="list-style-type: none"> <li>Assemble structure of parting blade and holder; good rigidity; adjustable parting range.</li> <li>The maximum parting diameter is 120mm.</li> </ul>	
		<p>Little squirrel series QE□□R/L</p>  <p>A272-A273</p>	<p>ZP□D□□</p>  <p>ZP□S□</p> 	<ul style="list-style-type: none"> <li>Inserts have three-dimensional chipbreaker with low cutting force and good performance on chip-breaking.</li> <li>The maximum parting diameter is 60mm.</li> </ul>	
		<p>Supplementary series QZQ□□R/L</p>  <p>A288</p>	<p>ZQMX□□</p> 	<ul style="list-style-type: none"> <li>Cutting edge strength is suitable for bad machining conditions.</li> <li>The maximum parting diameter is 70mm.</li> </ul>	
	Grooving and turning		<p>Little squirrel series QE□□R/L</p>  <p>A272-A273</p>	<p>Double cutting edges for parting ZT□D□□</p>  <p>Profile turning ZR□D□□</p>  <p>Single cutting edge for deep grooving ZT□S□□</p> 	<ul style="list-style-type: none"> <li>A single tool with multiple applications such as grooving, parting and profile turning, reducing tools categories needed.</li> <li>A multifunctional tool when used with grooving inserts. Suitable for profile machining.</li> <li>The maximum slot depth machinable is 30mm.</li> </ul>
			<p>Little squirrel series QE□□R/L</p>  <p>A272-A273</p>	<p>Precise grooving ZT□D□□-EG</p>  <p>Edge width 1.2~2.4mm</p>	<ul style="list-style-type: none"> <li>Grinded insert used for precise grooving</li> <li>Edge width can be anything between 1.0-6.5mm, customized according to users' needs.</li> <li>ZT□D□□-EG inserts: When edge width is between 1.2-2.4mm, the maximum cutting depth is 2.5mm. When edge width is above 2.4-6.5mm, the maximum cutting depth is 22mm.</li> </ul>
	<p>Little squirrel series QE□□R/L</p>  <p>A272-A273</p>	<p>Precise grooving ZT□D□□-EG</p>  <p>Edge width 2.4~6.5mm</p>			
Precise grooving		<p>Little squirrel series QE□□R/L</p>  <p>A273</p>	<p>Precise grooving ZT□D□□-EG</p>  <p>Edge width 1.2~2.4mm</p>	<ul style="list-style-type: none"> <li>Grinded insert used for precise grooving</li> <li>Edge width can be anything between 1.0-6.5mm, customized according to users' needs.</li> <li>ZT□D□□-EG inserts: When edge width is between 1.2-2.4mm, the maximum cutting depth is 2.5mm. When edge width is above 2.4-6.5mm, the maximum cutting depth is 22mm.</li> </ul>	
		<p>Little squirrel series QE□□R/L</p>  <p>A272-A273</p>	<p>Precise grooving ZT□D□□-EG</p>  <p>Edge width 2.4~6.5mm</p>		



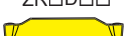

Machining application	Machining type	Applicable tools	Corresponding inserts	Tool features and parameters
External machining	Shallow grooving	 <p>QC series GQCR/L</p>  <p>A286</p>	<p>QC16/22□□□□</p> 	<ul style="list-style-type: none"> <li>• Fine grinding of blades with high precision.</li> <li>• Sharp edges and high machining accuracy.</li> <li>• Three finely ground cutting edges for good economy.</li> <li>• For cutting shallow grooves, groove width 0.5-4.8mm.</li> <li>• Maximum depth of cut 4mm.</li> </ul>
	Grooving and turning	 <p>Little squirrel series C□□-Q□□□/L□</p>  <p>A284</p>	<p>Grooving, Turning ZT□□□□</p>  <p>Profile turning ZR□□□□</p> 	<ul style="list-style-type: none"> <li>• By using inserts for grooving and profiling, one tool can be versatile, reducing the tool categories needed.</li> <li>• The maximum slot depth machinable is 13mm.</li> <li>• The minimum machining diameter is 27mm.</li> </ul>
Internal machining	Shallow grooving	 <p>QC series S□□□-QC□□□□/L□</p>  <p>A286</p>	<p>QC11/16/22□□□□</p> 	<ul style="list-style-type: none"> <li>• Fine grinding of blades with high precision.</li> <li>• Machining groove width 0.5-4.8mm.</li> <li>• Minimum machining diameter 16mm.</li> <li>• Maximum depth of cut 4mm.</li> </ul>
	Grooving and turning	 <p>Little squirrel series QF□□□□□H</p>  <p>A278-A281</p> <p>Little squirrel series QF□□□□□L</p>  <p>A282-A283</p>	<p>Grooving, Turning ZT□□□□</p>  <p>Profile turning ZR□□□□</p>  <p>Grooving, Turning ZT□□□□</p>  <p>Profile turning ZR□□□□</p> 	<ul style="list-style-type: none"> <li>• By using inserts for grooving and profiling, one tool can be versatile, reducing the tool categories needed.</li> <li>• Grooving diameter is 48-400mm.</li> <li>• Grooving depth is 10-30mm.</li> </ul> <ul style="list-style-type: none"> <li>• 90°holder, top clamping.</li> <li>• By using inserts for grooving and profiling, one tool can be versatile, reducing the tool categories needed.</li> <li>• Grooving diameter is 48~400mm.</li> <li>• Grooving depth is 10~30mm.</li> </ul>
Recess machining	 <p>Little squirrel series QX□□□□□□</p>  <p>A274</p>	<p>Grooving, Turning ZT□□□□</p>  <p>Profile turning ZR□□□□</p> 	<ul style="list-style-type: none"> <li>• The unique tool for recess machining.</li> <li>• Complete range of specifications, able to achieve various recess machining.</li> </ul>	

General turning  
Parting and grooving

Parting and grooving tools overview











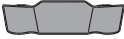

# TURNING / Parting and grooving tools

## Parting and grooving tools overview

General turning

Parting and grooving

Parting and grooving tools overview

Machining application	Machining type	Applicable tools	Corresponding inserts	Tool features and parameters
AI profiling	External machining	 <p>Little squirrel series QE□□R/L</p>  <p>A272-A273</p>	<p>Little squirrel series ZR□□-LH</p> 	<ul style="list-style-type: none"> <li>• The unique tool for profiling of Al material.</li> <li>• Cutting edge is designed to combine sharpness and strength, suitable for continuous and intermittent turning.</li> <li>• Used for external, surface and inner wall machining of Al wheel hub.</li> </ul>
	Inner wall and surface machining	 <p>Little squirrel series C40X□□</p>  <p>A284</p>		
Tools for aviation and aerospace industries	External machining	 <p>Little squirrel series QE□S□□N</p>  <p>A274</p>	<p>Little squirrel series ZIG□□□</p>  <p>Little squirrel series ZIMF□□</p> 	<ul style="list-style-type: none"> <li>• V-type locating, top clamping, precise locating, safe clamping.</li> <li>• Normal square-ended inserts and precise square-ended inserts are suitable for adhesive materials hard to machine such as Ni-base high-temperature alloy, Ti alloy and stainless steel, etc.</li> </ul>
	Non-standard Tools	 <p>Non-standard tools to match workpiece</p>	<p>Select and manufacture as required</p>	<ul style="list-style-type: none"> <li>• Tailor made solutions for machining various parts to satisfy your requirements.</li> </ul>

Little squirrel series

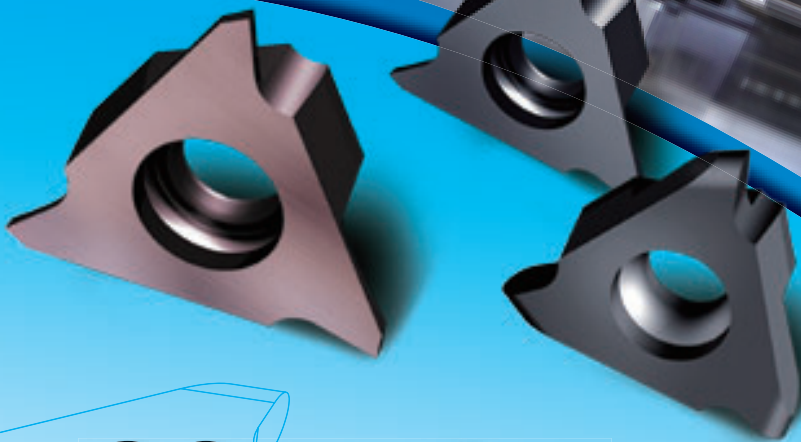

# QC series shallow grooving tools

**Machine industry shallow groove processing tool**

Widely used for shallow groove machining of shaft and ring parts in machinery industry

 **Shallow groove series tool grooving range**

Groove depth(mm)

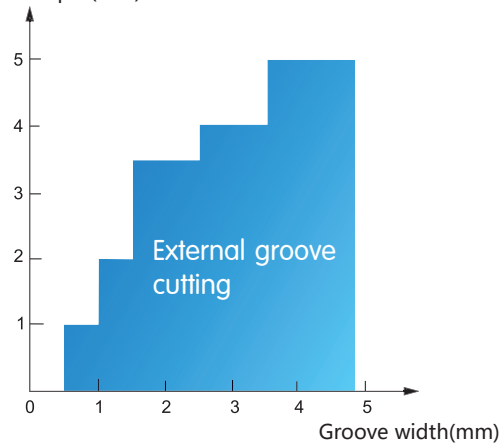

Groove depth(mm)

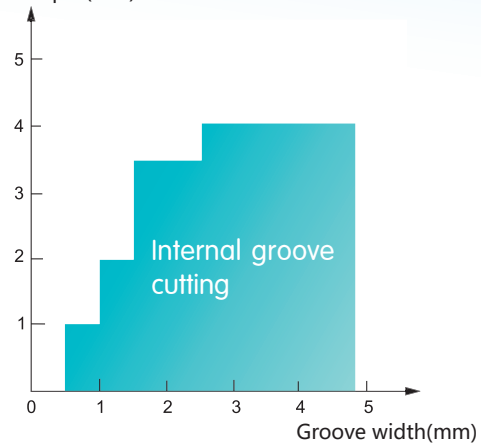

## Little-Squirrel Series

**Profile turning inserts for parting of aviation titanium alloy, high temperature alloy**

### **-NF**

#### **Single-headed precision profile turning inserts**

Sharp edge, small cutting force, good surface quality;  
Indexing accuracy reaches  $\pm 0.025\text{mm}$ , safe and stable clamping;  
Mainly applied in finishing of high-temperature alloy, titanium alloy.

### **-NM**

#### **Precision profile turning inserts**

Sharp edge, small cutting force, good surface quality;  
Indexing accuracy reaches  $\pm 0.025\text{mm}$ ;  
Highly economical, two edges available;  
Compatible with little squirrel tool holder, suitable for small depth profile finishing and semi-finishing of high-temperature alloy and Ti-alloy.





## -SM

### Single-headed groove turning inserts

Straight edge, excellent surface quality;  
Sharp edge, smaller cutting force;  
Good chip breaking;  
Mainly used for rough machining of high-temperature alloy and titanium alloy.



## -MM

### Straight edge groove turning inserts

High edge strength, sharp edge;  
Highly economical, two edges available, compatible with little squirrel tool holder;  
With special grades, suitable for roughing with small cutting depths of high-temperature alloy and titanium alloy.



#### Case

Insert: YBG105/ZIMF604N-SM  
Hardness of workpiece material: GH4169 (HB380)  
Cutting data:  $V_c=45\text{m/min}$ ,  $f=0.2\text{mm/r}$   
Coolant: Water



Products of company A



YBG105/ZIMF604N-SM

Conclusion: Under the same conditions, chip breaking performance is better and the time for stopping the removal of long winding chips is reduced.



# **-MG** Chipbreaker

## **Customized -MG chipbreaker series**

Suitable for parting ,grooving, profile turning and turning, etc. Easy machining and unobstructed chip flow lead to improved surface quality.

## **Human-centered design realizes various application of one single insert, reducing number of tools needed**

Inserts of the same edge with can work with corresponding tool holders to satisfy the requirements of external, internal and surface grooving and turning by using minimum numbers of inserts and tool holders, effectively reducing cost of tool storage and management.

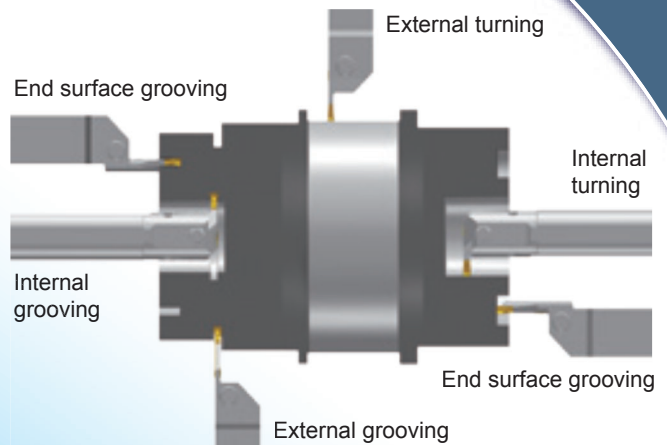

**The cutting force is reduced by 20%, and the vibration is diminished.**

## **Unique and professional structure design of parting inserts**

- A special flank structure is designed to reduce cutting resistant force by 20% and diminish vibration, which improves the surface quality.
- A special edge design requires less rigidity of machine. It can be used on low power machines.



## Little squirrel series

# -EG

### Precision grooving and profile turning inserts

Special chipbreaker design, suitable for precise grooving of low-carbon steel, stainless steel, adhesive materials and non-ferrous metal.

The tolerance of the edge width S of precise grooving and profiling inserts can reach  $\pm 0.025$ . Inserts can also be mounted on the corresponding specifications of original tool series.

#### -EG Precision grooving inserts

The edge width can be anything between **1.0-6.5MM** according to your requirements.

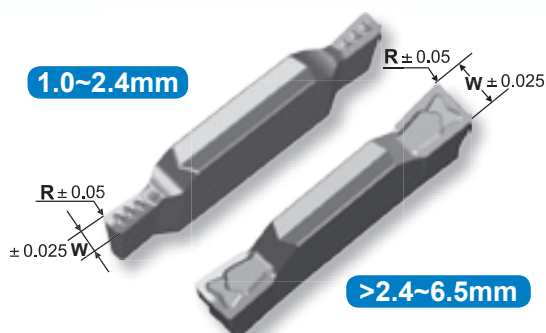

The width of the Little Squirrel series precise grooving inserts can be anything between 1.0mm to 6.5mm, which means products with any edge width or nose radius can be provided according to customers' requirements. The inserts are mainly used for precise grooving, such as sealing slot and locating slot, etc.

#### -EG Precision profile turning inserts

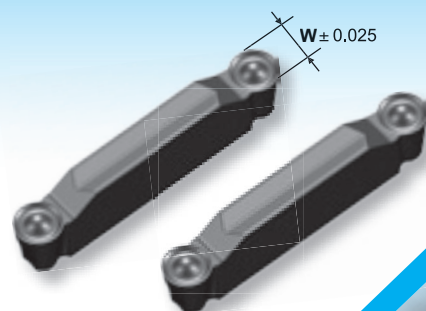

The Little Squirrel series precise profiling and turning inserts are mainly used for Precise grooving and profiling.

# -LC/-LH

### Profile turning inserts for Al

The special chipbreaker for aluminum profiling is designed to combine sharpness and strength of the cutting edge, effectively reducing the friction between chips and the rake face. The inserts are suitable for continuous and intermittent profiling of Al alloy.

Suitable for various machining of Al wheel boss periphery, surface and inner wall, etc.

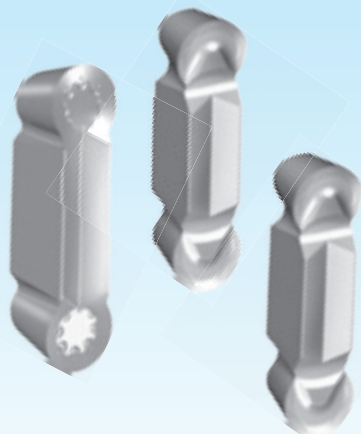



# TURNING Parting and grooving tools

Little squirrel series parting and grooving inserts

## Little squirrel series parting, grooving and profiling inserts code key

General turning

Parting and grooving

Little squirrel series parting and grooving inserts

### Insert applications

- ZP** > Parting    **ZT** > Grooving and turning
- ZR** > Profiling

### Code of locating slot

Code of locating slot	A	B	E	F	G	H	K	L
Corresponding edge width of inserts	1.5	2.0	2.5	3.0	4.0	5.0	6.0	8.0

### Code of cutting edge number

- S** > Single cutting edge    **D** > Double cutting edge

# ZP G D 04 04 - M G

### Cutting edge width

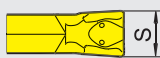

- 015=1.5mm
- 02=2.0mm
- 025=2.5mm
- 03=3.0mm
- 04=4.0mm
- 05=5.0mm
- 06=6.0mm
- 08=8.0mm

### Nose radius

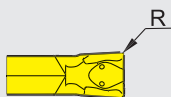

- 02=0.2mm
- 03=0.3mm
- 04=0.4mm
- 08=0.8mm

### Tolerance class

- M** > M-level tolerance
- E** > E-level tolerance

### Chipbreaker code

- G** > Curve edges universal chipbreaker, suitable for machining various materials
- M** > linear edges universal chipbreaker, suitable for machining various materials
- F** > Special chipbreaker



Parting inserts

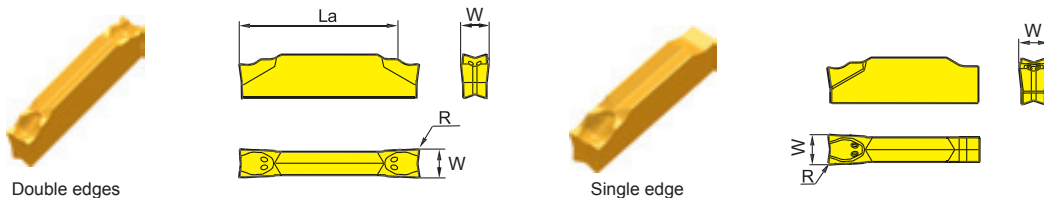

Type	Basic dimensions(mm)			Grade					
	W <sup>+0.1</sup> <sub>0</sub>	R±0.1	Cutting depth L <sub>amax</sub>	CVD Coating		PVD Coating		Cemented carbide	
				YBC151	YBC251	YBG205	YBG302		
Double edges	ZPAD01502-MG	1.5	0.2	12		○	★	○	
	ZPBD0202-MG	2.0	0.2	14		○	★	○	
	ZPED02502-MG	2.5	0.2	17		○	★	★	
	ZPFD0302-MG	3.0	0.2	17		○	★	○	
	ZPGD0402-MG	4.0	0.2	22		○	★	○	
	ZPHD0503-MG	5.0	0.3	22		○	★	○	
	ZPKD0604-MG	6.0	0.4	22		○	★	○	
Single edge	ZPES02502-MG	2.5	0.2			○	★	★	
	ZPFS0302-MG	3.0	0.2			○	★	○	
	ZPGS0402-MG	4.0	0.2			○	★	○	
	ZPHS0503-MG	5.0	0.3			○	★	○	
	ZPKS0604-MG	6.0	0.4			○	★	○	

Single edge tool for cutter plate only

★Recommended grade (always stock available) ●Available grade (always stock available) ○Make-to-order

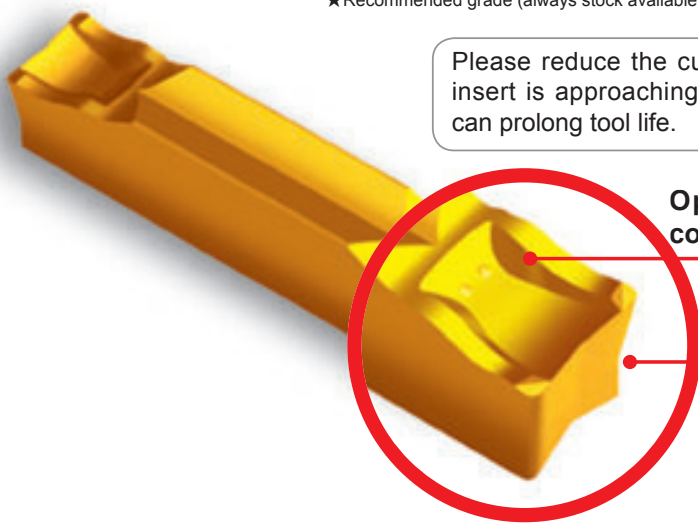

Please reduce the cutting speed by 30% when the insert is approaching the centre of workpiece. This can prolong tool life.

Optimal chipbreaker structure can control chip flow and curling well.

Cutting resistant force is reduced by 20% and vibration is diminished.

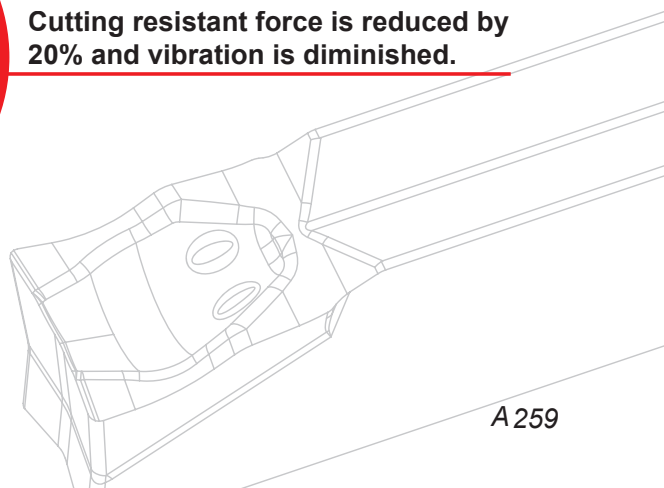

General turning

Parting and grooving

Little squirrel series parting and grooving inserts





# TURNING / Parting and grooving tools

Little squirrel series parting and grooving inserts

## Grooving and turning inserts

General turning

Parting and grooving

Little squirrel series parting and grooving inserts

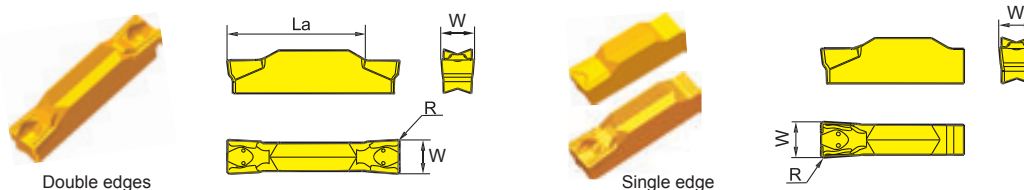

Type	Basic dimensions(mm)			Grade						
	$W^{+0.1}_0$	$R_{\pm 0.10}$	Cutting depth $L_{max}$	CVD Coating		PVD Coating			Cemented carbide	
				YBC151	YBC251	YBG202	YBG205	YBG302	YD101	
Double edges	ZTED02503-MG	2.5	0.3	17	○	○	●	★	★	
	ZTFD0303-MG	3.0	0.3	17	○	○	●	★	★	
	ZTGD0404-MG	4.0	0.4	22	●	○	●	★	★	
	ZTHD0504-MG	5.0	0.4	22		○	●	★	★	
	ZTKD0608-MG	6.0	0.8	22		○	●	★	★	
Single edge	ZTHS0504-MG	5.0	0.4			○	○	★	○	
	ZTKS0608-MG	6.0	0.8			○	○	★	○	

★ Recommended grade (always stock available) ● Available grade (always stock available) ○ Make-to-order



Type	Basic dimensions(mm)			Grade						
	W	$R_{\pm 0.1}$	Cutting depth $L_{max}$	CVD Coating		PVD Coating			Cemented carbide	
				YBC151	YBC251	YBG202	YBG205	YBG302	YD101	
Double edges	ZTAD01502-MM	1.5±0.03	0.2	12	○	○	●	★	○	
	ZTBD02002-MM	2.0±0.03	0.2	14	○	○	●	★	○	
	ZTED02503-MM	2.5±0.03	0.3	17	○	○	●	★	○	
	ZTFD0303-MM	3.0±0.03	0.3	17	○	○	●	★	○	
	ZTGD0404-MM	4.0±0.04	0.4	22	○	○	●	★	○	
	ZTHD0504-MM	5.0±0.04	0.4	22	○	○	●	★	○	
	ZTKD0608-MM	6.0±0.04	0.8	22	○	○	●	★	○	
	ZTLD0808-MM	8.0±0.05	0.8	28	○	○	●	★	○	

★ Recommended grade (always stock available) ● Available grade (always stock available) ○ Make-to-order





Precise grooving and turning inserts



1.0~2.4mm series

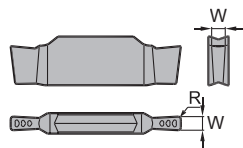

>2.4~6.5mm series

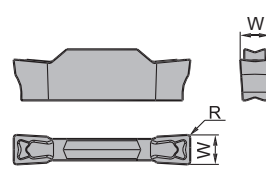

Type	Basic dimensions(mm)			Grade						
				CVD Coating		PVD Coating			Cemented carbide	
	$W \pm 0.025$	$R^{(2)} \pm 0.05$	Cutting depth $L_{max}$	YBC151	YBC251	YBG202	YBG205	YBG302	YD101	
Double edges	ZTCD□□□□□□ <sup>(1)</sup> -EG	1.0~1.6	See note. (2)	2.6	○	○	○	★	○	
		1.6~2.4		3.4	○	○	○	★	○	
	ZTED□□□□□□-EG	2.4~3.0		17	○	○	○	★	○	
	ZTFD□□□□□□-EG	3.0~3.8		17	○	○	○	★	○	
	ZTGD□□□□□□-EG	3.8~4.8		22	○	○	○	★	○	
	ZTHD□□□□□□-EG	4.8~5.8		22	○	○	○	★	○	
ZTKD□□□□□□-EG	5.8~6.5	22	○	○	○	★	○			

★Recommended grade (always stock available) ●Available grade (always stock available) ○Make-to-order

Note: (1) □ The code here in the description is determined by edge width and nose radius requested by customers. For example, when the customer requires an edge width of 3.5mm and a nose radius of 0.3mm, the description of the insert would be ZTFD03503-EG.

(2) The nose radius range is  $0.2 \leq R \leq 0.5$  on request.

General turning

Parting and grooving

Little squirrel series parting and grooving inserts





# TURNING / Parting and grooving tools

Little squirrel series parting and grooving inserts

General turning

Parting and grooving

Little squirrel series parting and grooving inserts

## Single-edge grooving and turning inserts for semi-finishing and roughing difficult-to-machine materials

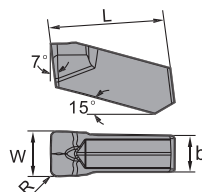

Type	Basic dimensions(mm)				Grade				
					PVD Coating				Cemented carbide
	W±0.05	R±0.1	b	L	YBG102	YBG202	YBG205	YBS103	YD101
ZIMF304N-NM	3	0.4	2.4	15.3	★	○	★	●	○
ZIMF406N-NM	4	0.6	3.2	15.3	★	○	★	●	○
ZIMF506N-NM	5	0.6	4.0	15.3	★	○	★	○	○
ZIMF608N-NM	6	0.8	4.0	15.3	★	○	★	○	○

★Recommended grade (always stock available) ●Available grade (always stock available) ○Make-to-order

## Single-edge grooving and turning inserts for semi-finishing and roughing difficult-to-machine materials

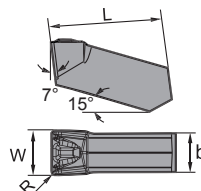

Type	Basic dimensions(mm)				Grade				
					PVD Coating				Cemented carbide
	W±0.05	R±0.1	b	L	YBG105	YBG212	YBG205	YBS103	YD101
ZIMF304N-SM	3	0.4	2.4	15.3	★	★		●	○
ZIMF404N-SM	4	0.4	3.2	15.3	★	★		○	○
ZIMF504N-SM	5	0.4	4.0	15.3	★	★		○	○
ZIMF604N-SM	6	0.4	5.1	15.3	★	★		○	○

★Recommended grade (always stock available) ●Available grade (always stock available) ○Make-to-order



Little squirrel series parting and grooving inserts

Profiling inserts

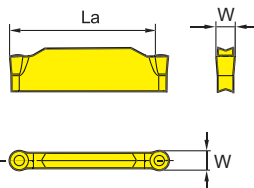

Type	Basic dimensions(mm)		Grade						
			CVD Coating		PVD Coating			Cemented carbide	
	$W^{+0.1}_0$	Cutting depth $L_{max}$	YBC151	YBC251	YBG202	YBG205	YBG302	YD101	
Double edges	ZRED025-MG	2.5	17.5		○	●	★	★	
	ZRFD03-MG	3.0	17		○	●	★	★	
	ZRGD04-MG	4.0	21		○	●	★	★	
	ZRHD05-MG	5.0	20		○	○	★	★	
	ZRKD06-MG	6.0	19		○	●	★	★	

★Recommended grade (always stock available) ●Available grade (always stock available) ○Make-to-order

Profiling inserts

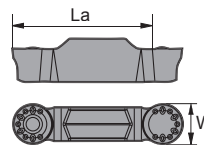

Type	Basic dimensions(mm)		Grade						
			CVD Coating		PVD Coating			Cemented carbide	
	$W \pm 0.025$	Cutting depth $L_{max}$	YBC151	YBC251	YBG105	YBG212	YBG302	YBS103	YD101
Double edges	ZRFD03-NM	3	17			★	★		●
	ZRGD04-NM	4	21			★	★		●
	ZRHD05-NM	5	20			★	★		○
	ZRKD06-NM	6	19			★	★		○

★Recommended grade (always stock available) ●Available grade (always stock available) ○Make-to-order

Precision profiling inserts

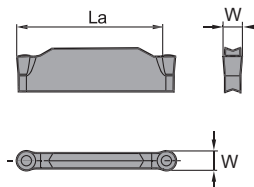

Type	Basic dimensions(mm)		Grade					
			CVD Coating		PVD Coating		Cemented carbide	
	$W \pm 0.025$	Cutting depth $L_{max}$	YBC151	YBC251	YBG202	YBG302	YD101	
Double edges	ZRFD03-EG	3.0	17		○		○	
	ZRGD04-EG	4.0	21		○		○	
	ZRHD05-EG	5.0	20		○		○	
	ZRKD06-EG	6.0	19		○		○	

★Recommended grade (always stock available) ●Available grade (always stock available) ○Make-to-order

General turning

Parting and grooving

Little squirrel series parting and grooving inserts



# TURNING Parting and grooving tools

Little squirrel series parting and grooving inserts

## Single-edge inserts for profiling materials hard to be machined

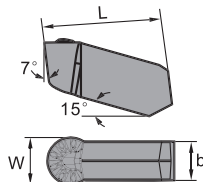

Type	Basic dimensions(mm)			Grade			
				PVD Coating			Cemented carbide
	$W \pm 0.025$	b	L	YBG102	YBG202	YBS103	YD101
ZIGQ3N-NM	3	2.4	15.3	★	○	●	○
ZIGQ4N-NM	4	3.2	15.3	★	○	●	○
ZIGQ5N-NM	5	4.0	15.3	★	○	○	○
ZIGQ6N-NM	6	5.0	15.3	★	○	○	○

★Recommended grade (always stock available) ●Available grade (always stock available) ○Make-to-order

General turning

Parting and grooving

Little squirrel series parting and grooving inserts

## Single-edge inserts for profiling materials hard to be machined

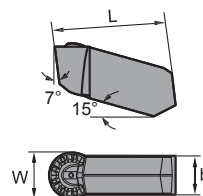

Type	Basic dimensions(mm)			Grade			
				PVD Coating			Cemented carbide
	$W \pm 0.025$	b	L	YBG105	YBG212	YBS103	YD101
ZIGQ3N-NF	3	2.4	15.3	★	★	●	
ZIGQ4N-NF	4	3.2	15.3	★	★	○	
ZIGQ5N-NF	5	4.0	15.3	★	★	○	
ZIGQ6N-NF	6	5.0	15.3	★	★	○	

★Recommended grade (always stock available) ●Available grade (always stock available) ○Make-to-order



Profiling inserts for Al

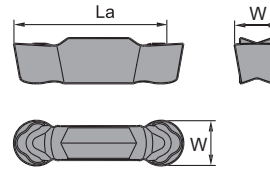

Type	Basic dimensions(mm)		Grade
	W±0.02	Cutting depth L <sub>amax</sub>	Cemented carbide
ZRKD06-LH	6.0	19	YD101
ZRLD08-LH	8.0	22	YD101

★Recommended grade (always stock available) ●Available grade (always stock available) ○Make-to-order

General turning

Parting and grooving

Little squirrel series parting and grooving inserts

Profiling inserts for Al

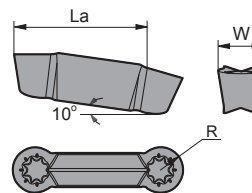

Type	Basic dimensions(mm)			Grade
	W±0.02	R	Cutting depth L <sub>amax</sub>	Cemented carbide
ZILD08-LC	8.0	4.0	22	YD101

★Recommended grade (always stock available) ●Available grade (always stock available) ○Make-to-order





# TURNING / Parting and grooving tools

## QC series shallow grooving inserts

### QC series shallow grooving inserts code key

#### ● Square head shallow groove inserts



**QC**

Shallow grooving inserts

**22**

Cutting edge length code	Inner tangent circle diameter(mm)
11	6.35
16	9.525
22	12.70



**R**

Direction	
Code	Form
R	Rightward 
L	Leftward 

**300**

Grooving width(mm)	
Code	Width
050	0.50
100	1.00
...	...
480	4.80

**R**

Inserts tip form	
Code	Form
R	Circular arc 
C	Chamfering 

**03**

Rounding or chamfering(mm)	
Code	Size
02	0.2
03	0.3
04	0.4

#### ● Round head shallow groove inserts



**QC**

Shallow grooving inserts

**22**

Cutting edge length code	Inner tangent circle diameter(mm)
11	6.35
16	9.525
22	12.70

**R**

Direction	
Code	Form
R	Rightward 
L	Leftward 

**300**

Grooving width(mm)	
Code	Width
050	0.50
100	1.00
...	...
480	4.80

**R**

Head form: round head

General turning

Parting and grooving

QC series shallow grooving inserts



## Square head shallow groove inserts



R-type shown

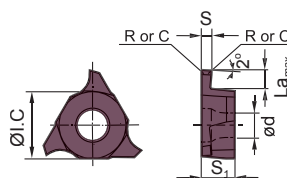

Type		Basic dimensions(mm)						Grade	
		$S \pm 0.025$	$La_{max}$	R/C	ØI.C	$S_1$	$\phi d$	PVD Coating	
								YBG202	YBG205
QC11R/L	120-R02	1.20	1.50	R0.2	6.35	3.18	2.8	○	○
	125-R02	1.25	1.50	R0.2	6.35	3.18	2.8	○	○
	145-R02	1.45	1.50	R0.2	6.35	3.18	2.8	○	○
	150-R02	1.50	1.50	R0.2	6.35	3.18	2.8	○	○
	200-R02	2.00	2.00	R0.2	6.35	3.18	2.8	○	○
	225-R02	2.25	2.00	R0.2	6.35	3.18	2.8	○	○
QC16R/L	110-R01	1.10	2.00	R0.1	9.525	3.18	4.4	○	○
	125-R02	1.25	2.00	R0.2	9.525	3.18	4.4	○	○
	145-R02	1.45	2.00	R0.2	9.525	3.18	4.4	○	○
	150-R02	1.50	2.00	R0.2	9.525	3.18	4.4	○	★
	175-R02	1.75	2.00	R0.2	9.525	3.18	4.4	○	○
	185-R02	1.85	2.50	R0.2	9.525	3.18	4.4	○	○
	200-R02	2.00	2.50	R0.2	9.525	3.18	4.4	○	★
	250-R02	2.50	2.50	R0.2	9.525	3.18	4.4	○	★
	300-R02	3.00	3.00	R0.2	9.525	3.18	4.4	○	★
QC22R/L	125-R02	1.25	2.00	R0.2	12.70	4.76	5.5	○	○
	145-R02	1.45	2.00	R0.2	12.70	4.76	5.5	○	○
	150-R02	1.50	3.50	R0.2	12.70	4.76	5.5	○	★
	175-R02	1.75	3.50	R0.2	12.70	4.76	5.5	○	○
	185-R02	1.85	3.50	R0.2	12.70	4.76	5.5	○	○
	200-R02	2.00	3.50	R0.2	12.70	4.76	5.5	○	★
	230-R02	2.30	3.50	R0.2	12.70	4.76	5.5	○	○
	250-R03	2.50	4.00	R0.3	12.70	4.76	5.5	○	★
	265-R03	2.65	4.00	R0.3	12.70	4.76	5.5	○	○
	280-R03	2.80	4.00	R0.3	12.70	4.76	5.5	○	○

★Recommended grade (always stock available) ●Available grade (always stock available) ○Make-to-order

General turning

Parting and grooving

QC series shallow grooving inserts



### Square head shallow groove inserts



R-type shown

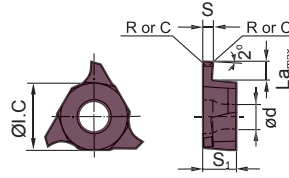

Type		Basic dimensions(mm)						Grade	
		S $\pm 0.025$	La <sub>max</sub>	R/C	ØI.C	S <sub>1</sub>	ød	PVD Coating	
								YBG202	YBG205
QC22R/L	300-R03	3.00	4.00	R0.3	12.70	4.76	5.5	○	★
	320-R03	3.20	4.00	R0.3	12.70	4.76	5.5	○	○
	330-R03	3.30	4.00	R0.3	12.70	4.76	5.5	○	○
	350-R03	3.50	5.00	R0.3	12.70	4.76	5.5	○	★
	400-R04	4.00	5.00	R0.4	12.70	4.76	5.5	○	★
	430-R04	4.30	5.00	R0.4	12.70	4.76	5.5	○	○
	450-R04	4.50	5.00	R0.4	12.70	4.76	5.5	○	○
	480-R04	4.80	5.00	R0.4	12.70	5.06	5.5	○	○

★Recommended grade (always stock available) ●Available grade (always stock available) ○Make-to-order

Example of special specification customization:

1. Custom-made insert width of 1.6mm, the tip form of the arc form, the arc radius of 0.3mm right blade, I.C value of 12.7mm, then the custom-made insert model is QC22R160-R03.
2. Customized edge width range: QC11: 0.50~3.0mm; QC16: 0.50~3.0mm; QC22: 1.0~4.8mm.

### Round head shallow groove inserts



R-type shown

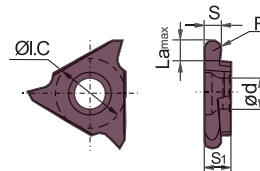

Type		Basic dimensions(mm)						Grade	
		S $\pm 0.025$	La <sub>max</sub>	R/C	ØI.C	S <sub>1</sub>	ød	PVD Coating	
								YBG202	YBG205
QC16R/L	200R	2.00	2.50	1.00	12.70	3.18	4.4	○	○
	300R	3.00	2.50	1.50	12.70	3.18	4.4	○	○
QC22R/L	100R	1.00	2.00	0.50	12.70	4.76	5.5	○	○
	150R	1.50	3.50	0.75	12.70	4.76	5.5	○	○
	200R	2.00	3.50	1.00	12.70	4.76	5.5	○	○
	250R	2.50	4.00	1.25	12.70	4.76	5.5	○	○
	300R	3.00	4.00	1.50	12.70	4.76	5.5	○	○
	400R	4.00	5.00	2.00	12.70	4.76	5.5	○	○

★Recommended grade (always stock available) ●Available grade (always stock available) ○Make-to-order

Example of special specification customization:

Custom-made inserts width of 1.6mm, the tip form of the arc form, the arc radius of 0.8mm right insert, then the custom-made insert model is QC22R160R.



ZQMX series

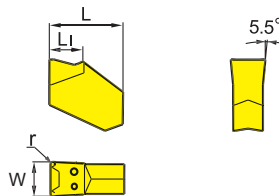

Type	Basic dimensions(mm)				Grade		
					CVD Coating	Cemented carbide	
	L1	W	r	L	YBC251	YC40	YD201
ZQMX3N11-1E	4.4	3.125	0.3	11	●	●	●
ZQMX4N11-1E	4.95	4.125	0.3	11	●	●	●
ZQMX5N11-1E	5.0	5.125	0.3	11	●	●	●
ZQMX6N11-1E	5.28	6.4	0.3	11	●	●	○
ZQMX7N11-1E	4.53	7.05	0.3	14		○	

★Recommended grade (always stock available) ●Available grade (always stock available) ○Make-to-order

General turning

Parting and grooving

Supplementary series parting and grooving inserts

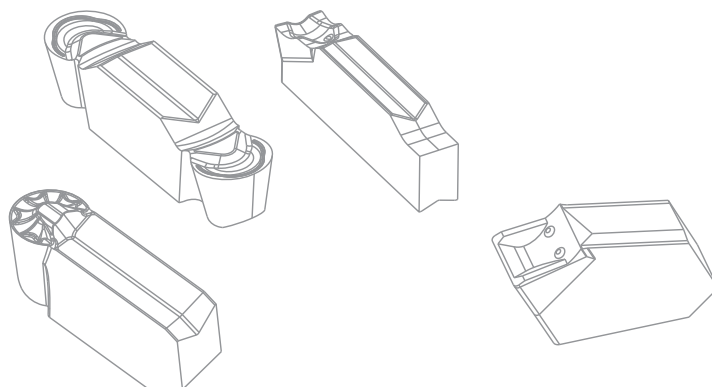



# TURNING Parting and grooving tools

Little squirrel series parting and grooving tools

## Little squirrel series parting and grooving tools code key

### ● External and surface turning

General turning

Parting and grooving

Little squirrel series parting and grooving tools

Code of grooving tools

Machining mode

**E** > External cutting    **F** > End surface cutting

Code of locating slot

Accords with locating slot code of insert and corresponds to certain range of insert edge width

Code of edge number of corresponding inserts

**S** > Single cutting edge    **D** > Double cutting edge

**Q** **E** **G** **D** - **2525** **R** **13**  
**32** **N**

**Q** **F** **G** **D** **2525** **R** **22** **S** - **130** **H**

Nose height and width of tool holder

Left and right hand of tool

**R** > Right    **L** > Left    **N** > Both are acceptable

Maximum cutting depth

Supplementary code

S: Strengthened tool holder for external and surface deep grooving

The minimum diameter of end surface grooving tools for initial machining

Holder type of end surface grooving tools

**H** > Straight holder    **L** > 90° holder





● Holder for parting blade

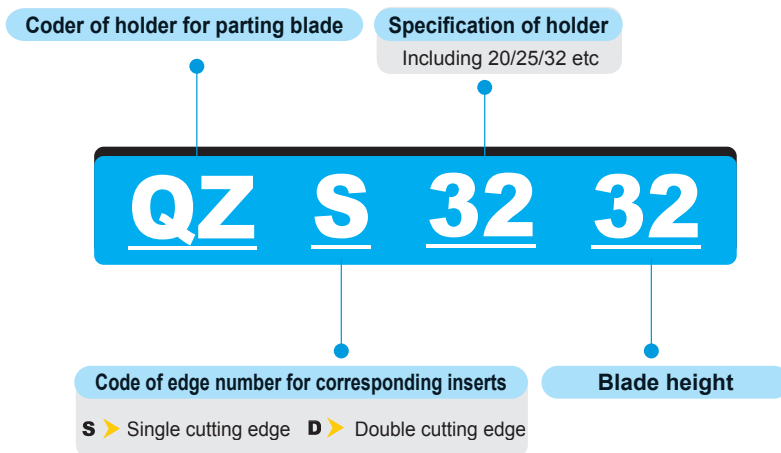

General turning

Parting and grooving

Little squirrel series parting and grooving tools

● Internal machining

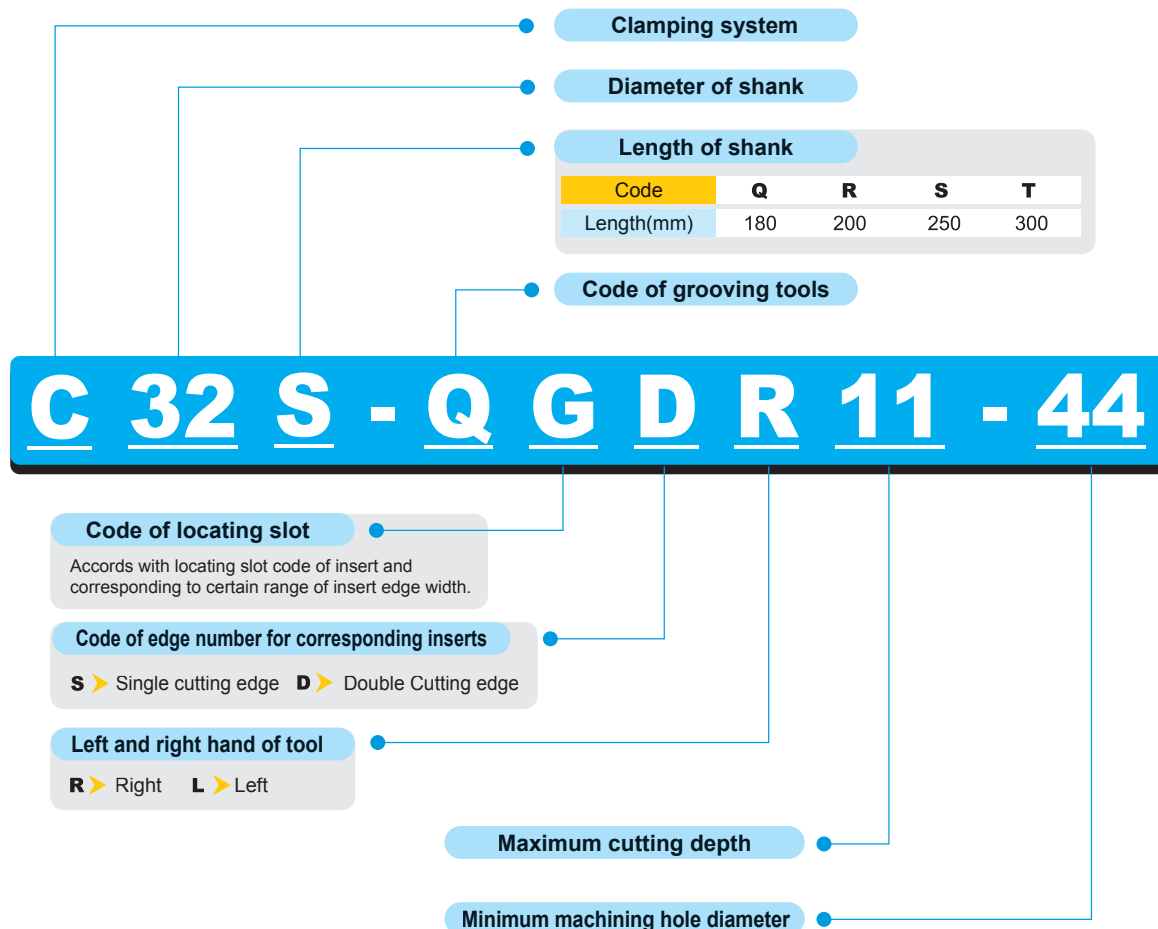



# TURNING / Parting and grooving tools

Little squirrel series parting and grooving tools

## External parting, grooving and turning tools

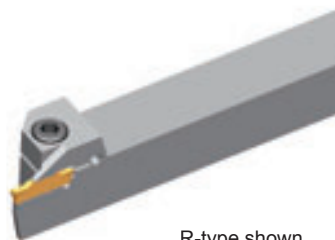

R-type shown

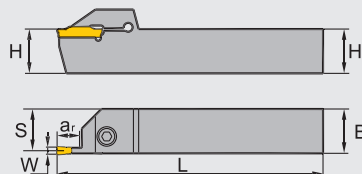

General turning

Parting and grooving

Little squirrel series parting and grooving tools

Type		Stock		Basic dimensions(mm)					Applicable inserts	Screw	Wrench
		R	L	H×B	L	S	W	ar max			
<b>QEAD</b>	1212R/L07	▲	▲	12×12	125	11.4	1.5	7	Z□AD015□□	GB70-85-M4×12	WH30L
	1212R/L12	▲	▲	12×12	125	11.4	1.5	12	Z□AD015□□		
	1616R/L07	▲	▲	16×16	125	15.4	1.5	7	Z□AD015□□		
	1616R/L12	▲	▲	16×16	125	15.4	1.5	12	Z□AD015□□		
	2020R/L07	▲	▲	20×20	125	19.4	1.5	7	Z□AD015□□		
	2020R/L12	▲	▲	20×20	125	19.4	1.5	12	Z□AD015□□		
<b>QEBD</b>	1212R/L07	▲	▲	12×12	125	11.2	2	7	Z□BD02□□	GB70-85-M4×12	WH30L
	1212R/L10	▲	▲	12×12	125	11.2	2	10	Z□BD02□□		
	1212R/L14	▲	▲	12×12	125	11.2	2	14	Z□BD02□□		
	1616R/L07	▲	▲	16×16	125	15.2	2	7	Z□BD02□□		
	1616R/L10	▲	▲	16×16	125	15.2	2	10	Z□BD02□□		
	1616R/L14	▲	▲	16×16	125	15.2	2	14	Z□BD02□□		
	2020R/L07	▲	▲	20×20	125	19.2	2	7	Z□BD02□□		
	2020R/L10	▲	▲	20×20	125	19.2	2	10	Z□BD02□□		
	2020R/L14	▲	▲	20×20	125	19.2	2	14	Z□BD02□□		
	2525R/L07	▲	▲	25×25	150	24.2	2	7	Z□BD02□□		
	2525R/L10	▲	▲	25×25	150	24.2	2	10	Z□BD02□□		
	2525R/L14	▲	▲	25×25	150	24.2	2	14	Z□BD02□□		
<b>QEED</b>	1616R/L10	▲	▲	16×16	125	15	2.5	10	Z□ED025□□	GB70-85-M5×20	WH40L
	1616R/L17	▲	▲	16×16	125	15	2.5	17	Z□ED025□□		
	2020R/L10	▲	▲	20×20	125	19	2.5	10	Z□ED025□□		
	2020R/L17	▲	▲	20×20	125	19	2.5	17	Z□ED025□□		
	2525R/L10	▲	▲	25×25	150	24	2.5	10	Z□ED025□□		
	2525R/L17	▲	▲	25×25	150	24	2.5	17	Z□ED025□□		
<b>QEFD</b>	1616R/L10	▲	▲	16×16	125	14.8	3	10	Z□FD03□□	GB70-85-M5×20	WH40L
	1616R/L17	▲	▲	16×16	125	14.8	3	17	Z□FD03□□		
	2020R/L10	▲	▲	20×20	125	18.8	3	10	Z□FD03□□		
	2020R/L17	▲	▲	20×20	125	18.8	3	17	Z□FD03□□		
	2525R/L10	▲	▲	25×25	150	23.8	3	10	Z□FD03□□		
	2525R/L17	▲	▲	25×25	150	23.8	3	17	Z□FD03□□		
<b>QEGD</b>	2020R/L13	▲	▲	20×20	140	18.5	4	13	Z□GD04□□	GB70-85-M6×20	WH50L
	2020R/L22	▲	▲	20×20	140	18.5	4	22	Z□GD04□□		
	2525R/L13	▲	▲	25×25	150	23.5	4	13	Z□GD04□□		

▲Stock available    △Make-to-order



External parting, grooving and turning tools

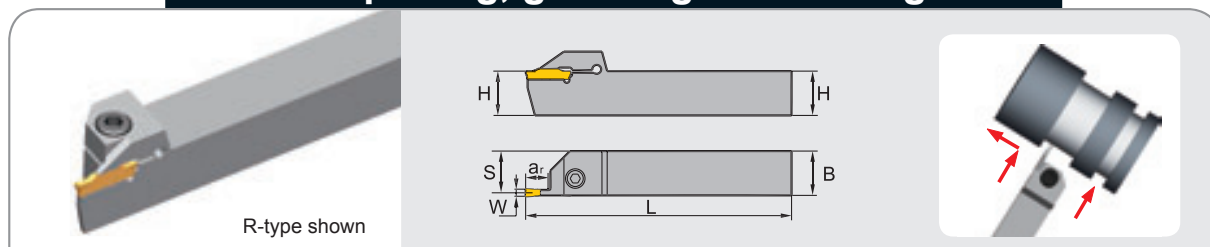

Type		Stock		Basic dimensions(mm)					Applicable inserts	Screw	Wrench
		R	L	H×B	L	S	W	ar max			
QEGD	2525R/L22	▲	▲	25×25	150	23.5	4	22	Z□GD04□□	GB70-85-M6×20	WH50L
	3232R/L13	▲	▲	32×32	170	30.5	4	13	Z□GD04□□		
	3232R/L22	▲	▲	32×32	170	30.5	4	22	Z□GD04□□		
QEHD	2525R/L13	▲	▲	25×25	150	23	5	13	Z□HD05□□	GB70-85-M6×20	WH50L
	2525R/L22	▲	▲	25×25	150	23	5	22	Z□HD05□□		
QEHS	2525N30	▲	▲	25×25	150	12.5	5	30	Z□HS05□□		
QEHD	3232R/L13	▲	▲	32×32	170	30	5	13	Z□HD05□□		
	3232R/L22	▲	▲	32×32	170	30	5	22	Z□HD05□□		
QEHS	3232N30	▲	▲	32×32	170	16	5	30	Z□HS05□□		
QEKD	2525R/L13	▲	▲	25×25	150	22.6	6	13	Z□KD06□□	GB70-85-M6×20	WH50L
	2525R/L22	▲	▲	25×25	150	22.6	6	22	Z□KD06□□		
QEKD	3232R/L13	▲	▲	32×32	170	29.6	6	13	Z□KD06□□		
QEKD	3232R/L22	▲	▲	32×32	170	29.6	6	22	Z□KD06□□		
	3232N30	▲	▲	32×32	170	16	6	30	Z□KS06□□		
QEKD	2525R/L16	▲	▲	25×25	150	22	8	16	ZTLD0808-MM		
QELD	2525R/L25	▲	▲	25×25	150	22	8	25	ZTLD0808-MM	GB70-85-M6×20	WH50L
	3232R/L28	▲	▲	32×32	170	29	8	28	ZTLD0808-MM	GB70-85-M8×30	WH60L

▲Stock available    △Make-to-order

Precision grooving and turning tools

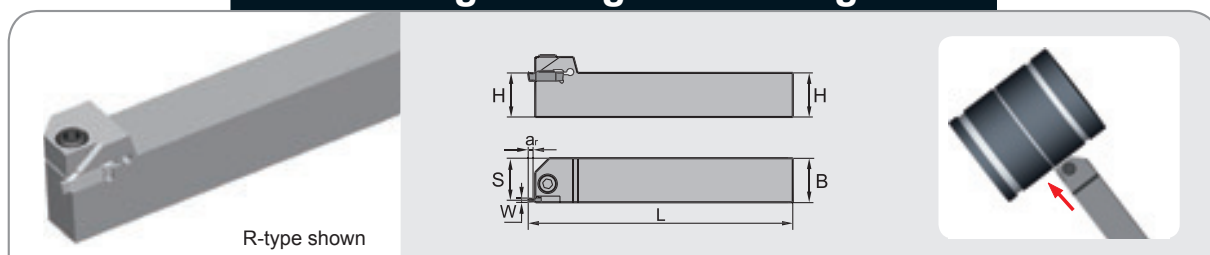

Type		Stock		Basic dimensions(mm)					Applicable inserts	Screw	Wrench
		R	L	H×B	L	S	W	ar max			
QECD	1616R/L025	△	△	16×16	125	14.75	1.0~2.4	2.5	ZTCD□□□□□□-EG	GB70-85-M5×20	WH40L
	2020R/L025	▲	△	20×20	125	18.75				GB70-85-M6×20	WH50L
	2525R/L025	▲	△	25×25	150	23.75				GB70-85-M6×20	WH50L

▲Stock available    △Make-to-order

General turning

Parting and grooving

Little squirrel series parting and grooving tools



# TURNING Parting and grooving tools

Little squirrel series parting and grooving tools

## External relief groove machining and profiling tools

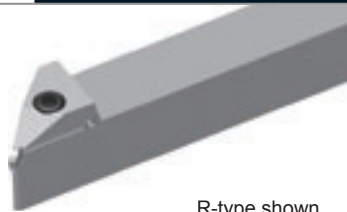

R-type shown

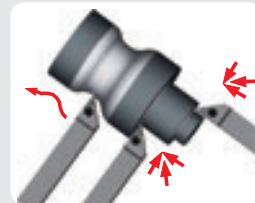
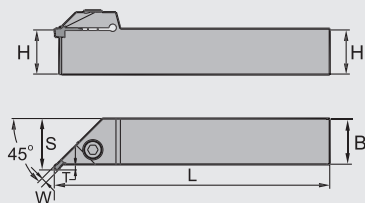

Type	Stock	Basic dimensions(mm)							Applicable inserts	Screw	Wrench
		R	L	H×B	L	S	W	ar max			
<b>QXFD</b>	2020R/L03-45	△	△	20×20	125	23			ZR(T)FD03-□□	GB70-85-M6×20	WH50L
	2525R/L03-45	△	△	25×25	150	28	3.0	3.0			
	3232R/L03-45	△	△	32×32	170	35					
<b>QXGD</b>	2020R/L03-45	△	△	20×20	125	23			ZR(T)GD04-□□		
	2525R/L03-45	△	△	25×25	150	28	4.0	3.0			
	3232R/L03-45	△	△	32×32	170	35					
<b>QXHD</b>	2020R/L04-45	△	△	20×20	125	24			ZR(T)HD05-□□		
	2525R/L04-45	△	△	25×25	150	29	5.0	4.0			
	3232R/L04-45	△	△	32×32	170	36					
<b>QXKD</b>	2020R/L04-45	△	△	20×20	125	24			ZR(T)KD06-□□		
	2525R/L04-45	△	△	25×25	150	29	6.0	4.0			
	3232R/L04-45	△	△	32×32	170	36					

▲Stock available    △Make-to-order

## External grooving tools for difficult-to-machine materials

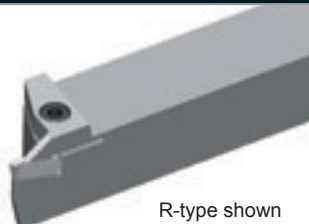

R-type shown

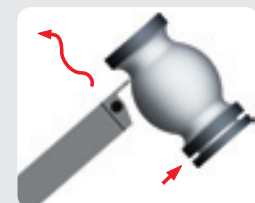
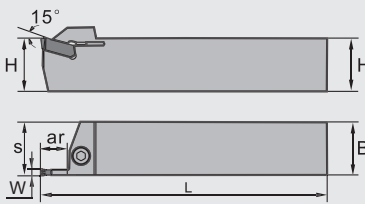

Type	Stock	Basic dimensions(mm)							Applicable inserts	Screw	Wrench
		R	L	H×B	L	S	W	ar max			
<b>QEFS</b>	2525R/L12-3N	△	△	25×25	150	25.3	3	12	ZIGQ3N-□□ ZIMF304N-□□	GB70-85-M6×20	WH50L
	3232R/L22-3N	△	△	32×32	170	32.3	3	22			
<b>QEGS</b>	2525R/L12-4N	△	△	25×25	150	25.3	4	12	ZIGQ4N-□□ ZIMF40□N-□□		
	3232R/L22-4N	△	△	32×32	170	32.3	4	22			
<b>QEHS</b>	2525R/L12-5N	△	△	25×25	150	25.4	5	12	ZIGQ5N-□□ ZIMF50□N-□□		
	3232R/L22-5N	△	△	32×32	170	32.4	5	22			
<b>QEKs</b>	2525R/L12-6N	△	△	25×25	150	25.4	6	12	ZIGQ6N-□□ ZIMF60□N-□□		
	3232R/L22-6N	△	△	32×32	170	32.4	6	22			

▲Stock available    △Make-to-order

General turning

Parting and grooving

Little squirrel series parting and grooving tools

Blade for external parting

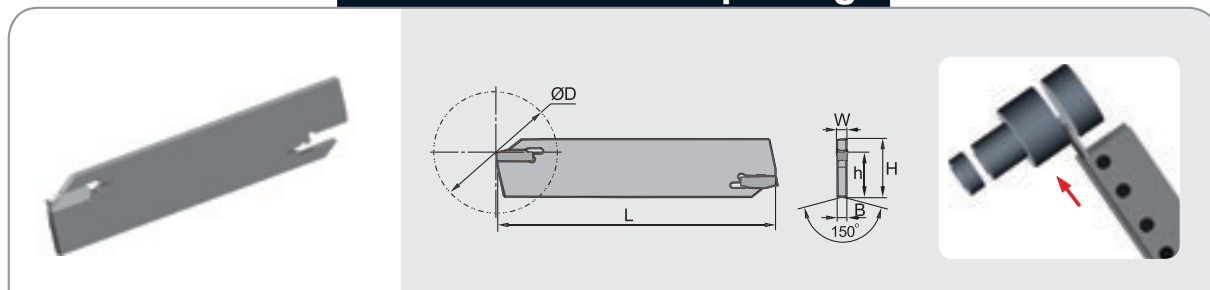

Type	Stock	Basic dimensions(mm)						Applicable inserts	Wrench
		L	H	h	B	W	ØD <sub>max</sub> (Maximum parting diameter)		
QEES26N	▲	110	26	19	2	2.5	60	ZPES02502-MG	W50RL
QEFS26N	▲	110	26	19	2.4	3	60	ZPFS0302-MG	
QEGS26N	▲	110	26	19	3.2	4	70	ZPGS0402-MG	
QEHS26N	▲	110	26	19	4	5	70	ZPHS0503-MG	
QEKS26N	▲	110	26	19	5	6	70	ZPKS0604-MG	
QEES32N	▲	150	32	24.6	2	2.5	100	ZPES02502-MG	
QEFS32N	▲	150	32	24.6	2.4	3	100	ZPFS0302-MG	
QEGS32N	▲	150	32	24.6	3.2	4	120	ZPGS0402-MG	
QEHS32N	▲	150	32	24.6	4	5	120	ZPHS0503-MG	
QEKS32N	▲	150	32	24.6	5	6	120	ZPKS0604-MG	

▲Stock available

△Make-to-order

Holder for blade used for external parting

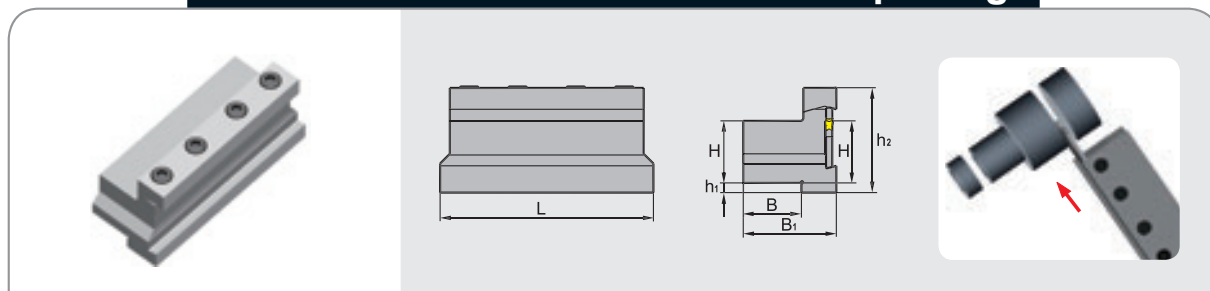

Type	Stock	Basic dimensions(mm)						Clamp	Screw	Wrench
		L	H	h <sub>1</sub>	h <sub>2</sub>	B	B <sub>1</sub>			
QZS2026	▲	86	20	10	46.6	19	38	QZC26	GB70-85-M6×20	WH50L
QZS2526	▲	86	25	5	46.6	23	42	QZC26		
QZS3226	▲	86	30	3	51.6	30	48	QZC26		
QZS2032	▲	110	20	13	50	19	38	QZC32		
QZS2532	▲	110	25	8	50	23	42	QZC32		
QZS3232	▲	110	32	5	54	30	48	QZC32		

▲Stock available

△Make-to-order

General turning

Parting and grooving

Little squirrel series parting and grooving tools





# TURNING / Parting and grooving tools

Little squirrel series parting and grooving tools

## End surface grooving and turning tools



L-type shown

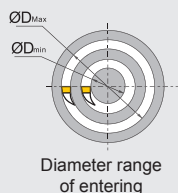
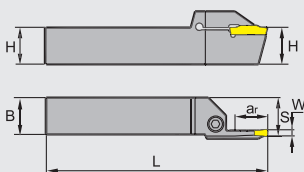



Diameter range of entering



General turning

Parting and grooving

Little squirrel series parting and grooving tools



Type	Stock		Basic dimensions(mm)						Applicable inserts	Screw	Wrench	
	R	L	H×B	L	S	W	ar max	ØD (min-max)				
<b>QFFD</b>	2020R/L7-48H	▲	▲	20×20	150	21	3	7	48-66	ZTFD0303-□□	GB70-85-M6×20	WH50L
	2020R/L10-48H	▲	▲	20×20	150	21	3	10	48-66			
	2525R/L10-48H	▲	▲	25×25	150	26	3	10	48-66			
	2525R/L17-48H	▲	▲	25×25	150	26	3	17	48-66			
	2020R/L7-60H	△	△	20×20	150	21	3	7	60-80			
	2020R/L10-60H	△	△	20×20	150	21	3	10	60-80			
	2525R/L10-60H	▲	▲	25×25	150	26	3	10	60-80			
	2525R/L17-60H	▲	▲	25×25	150	26	3	17	60-80			
	2020R/L7-74H	△	△	20×20	150	21	3	7	74-110			
	2020R/L10-74H	△	▲	20×20	150	21	3	10	74-110			
	2525R/L10-74H	▲	▲	25×25	150	26	3	10	74-110			
	2525R/L17-74H	▲	▲	25×25	150	26	3	17	74-110			
	2020R/L7-100H	△	△	20×20	150	21	3	7	100-150			
	2020R/L10-100H	△	△	20×20	150	21	3	10	100-150			
2525R/L10-100H	▲	▲	25×25	150	26	3	10	100-150				
2525R/L17-100H	▲	▲	25×25	150	26	3	17	100-150				
<b>QFGD</b>	2020R/L10-52H	△	△	20×20	150	21	4	10	52-72	ZTGD0404-□□	GB70-85-M6×20	WH50L
	2525R/L13-52H	▲	▲	25×25	150	26	4	13	52-72			
	2020R/L15-52H	△	△	20×20	150	21	4	15	52-72			
	2525R/L22-52H	▲	▲	25×25	150	26	4	22	52-72			
	2020R/L10-64H	△	▲	20×20	150	21	4	10	64-100			
	2525R/L13-64H	▲	▲	25×25	150	26	4	13	64-100			
	2020R/L15-64H	△	△	20×20	150	21	4	15	64-100			
	2525R/L22-64H	▲	▲	25×25	150	26	4	22	64-100			
	2020R/L10-90H	△	△	20×20	150	21	4	10	90-140			
	2525R/L13-90H	▲	▲	25×25	150	26	4	13	90-140			
	2020R/L15-90H	△	△	20×20	150	21	4	15	90-140			
	2525R/L22-90H	▲	▲	25×25	150	26	4	22	90-140			
	2020R/L10-130H	△	△	20×20	150	21	4	10	130-230			
	2525R/L13-130H	▲	▲	25×25	150	26	4	13	130-230			
2020R/L15-130H	△	△	20×20	150	21	4	15	130-230				
2525R/L22-130H	▲	▲	25×25	150	26	4	22	130-230				

▲Stock available    △Make-to-order

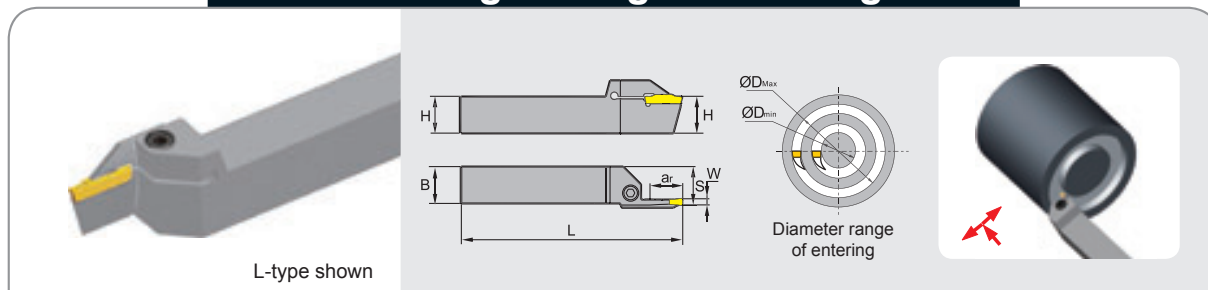

## End surface grooving and turning tools



Type	Stock		Basic dimensions(mm)						Applicable inserts	Screw	Wrench	
	R	L	H×B	L	S	W	ar max	ØD (min-max)				
<b>QFHD</b>	<b>2525R/L13-58H</b>	▲	▲	25×25	150	26	5	13	58-96	ZTHD0504-□□	GB70-85-M6×20	WH50L
	<b>2525R/L22-58H</b>	▲	▲	25×25	150	26	5	22	58-96			
	<b>2525R/L13-86H</b>	△	▲	25×25	150	26	5	13	86-140			
	<b>2525R/L22-86H</b>	▲	▲	25×25	150	26	5	22	86-140			
	<b>2525R/L13-130H</b>	▲	▲	25×25	150	26	5	13	130-200			
	<b>2525R/L22-130H</b>	▲	▲	25×25	150	26	5	22	130-200			
	<b>2525R/L13-185H</b>	▲	▲	25×25	150	26	5	13	185-400			
	<b>2525R/L22-185H</b>	▲	▲	25×25	150	26	5	22	185-400			
<b>QFHS</b>	<b>2525R/L30-185H</b>	△	△	25×25	150	26	5	30	185-400	ZTHS0504-MG		
<b>QFKD</b>	<b>2525R/L13-60H</b>	▲	▲	25×25	150	26	6	13	60-100	ZTKD0608-□□	GB70-85-M6×20	WH50L
	<b>2525R/L22-60H</b>	▲	▲	25×25	150	26	6	22	60-100			
	<b>2525R/L13-88H</b>	△	▲	25×25	150	26	6	13	88-180			
	<b>2525R/L22-88H</b>	▲	▲	25×25	150	26	6	22	88-180			
	<b>2525R/L13-160H</b>	▲	▲	25×25	150	26	6	13	160-400			
	<b>2525R/L22-160H</b>	▲	▲	25×25	150	26	6	22	160-400			
<b>QFKS</b>	<b>2525R/L30-160H</b>	△	△	25×25	150	26	6	30	160-400	ZTKS0608-MG		
<b>QFLD</b>	<b>2525R/L25-75H</b>	▲	▲	25×25	150	27	8	25	75-150	ZTLD0808-MM	GB70-85-M6×20	WH50L
	<b>2525R/L25-140H</b>	▲	▲	25×25	150	27	8	25	140-400	ZTLD0808-MM	GB70-85-M6×20	WH50L
	<b>3232R/L28-140H</b>	▲	▲	32×32	170	30	8	28	140-400	ZTLD0808-MM	GB70-85-M8×30	WH60L

▲Stock available    △Make-to-order

General turning

Parting and grooving

Little squirrel series parting and grooving tools



# TURNING / Parting and grooving tools

Little squirrel series parting and grooving tools

## End surface grooving and turning tools



RR-type shown

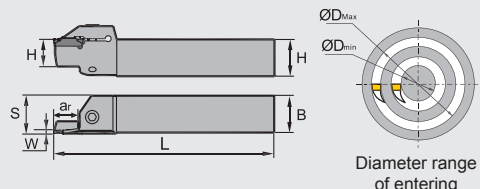

General turning

Parting and grooving

Little squirrel series parting and grooving tools

Type	Stock	Basic dimensions(mm)							Applicable inserts	Screw	Wrench
		H×B	L	S	W	ar max	ØD (min-max)				
<b>QFFD</b>	2020RR7-48H	△	20×20	150	21	3	7	48-66	ZTFD0303-□□	GB70-85-M6×20	WH50L
	2020RR10-48H	△	20×20	150	21	3	10	48-66			
	2525RR10-48H	△	25×25	150	26	3	10	48-66			
	2525RR17-48H	△	25×25	150	26	3	17	48-66			
	2020RR7-60H	△	20×20	150	21	3	7	60-80			
	2020RR10-60H	△	20×20	150	21	3	10	60-80			
	2525RR10-60H	△	25×25	150	26	3	10	60-80			
	2525RR17-60H	△	25×25	150	26	3	17	60-80			
	2020RR7-74H	△	20×20	150	21	3	7	74-110			
	2020RR10-74H	△	20×20	150	21	3	10	74-110			
	2525RR10-74H	△	25×25	150	26	3	10	74-110			
	2525RR17-74H	△	25×25	150	26	3	17	74-110			
	2020RR7-100H	△	20×20	150	21	3	7	100-150			
	2020RR10-100H	△	20×20	150	21	3	10	100-150			
2525RR10-100H	△	25×25	150	26	3	10	100-150				
2525RR17-100H	△	25×25	150	26	3	17	100-150				
<b>QFGD</b>	2020RR10-52H	△	20×20	150	21	4	10	52-72	ZTGD0404-□□	GB70-85-M6×20	WH50L
	2020RR15-52H	△	20×20	150	26	4	15	52-72			
	2525RR13-52H	△	25×25	150	21	4	13	52-72			
	2525RR22-52H	△	25×25	150	26	4	22	52-72			
	2020RR10-64H	△	20×20	150	21	4	10	64-100			
	2020RR15-64H	△	20×20	150	26	4	15	64-100			
	2525RR13-64H	△	25×25	150	21	4	13	64-100			
	2525RR22-64H	△	25×25	150	26	4	22	64-100			
	2020RR10-90H	△	20×20	150	21	4	10	90-140			
	2020RR15-90H	△	20×20	150	26	4	15	90-140			
	2525RR13-90H	△	25×25	150	21	4	13	90-140			
	2525RR22-90H	△	25×25	150	26	4	22	90-140			
	2020RR10-130H	△	20×20	150	21	4	10	130-230			
	2020RR15-130H	△	20×20	150	26	4	15	130-230			
2525RR13-130H	△	25×25	150	21	4	13	130-230				
2525RR22-130H	△	25×25	150	26	4	22	130-230				

▲Stock available    △Make-to-order



## End surface grooving and turning tools

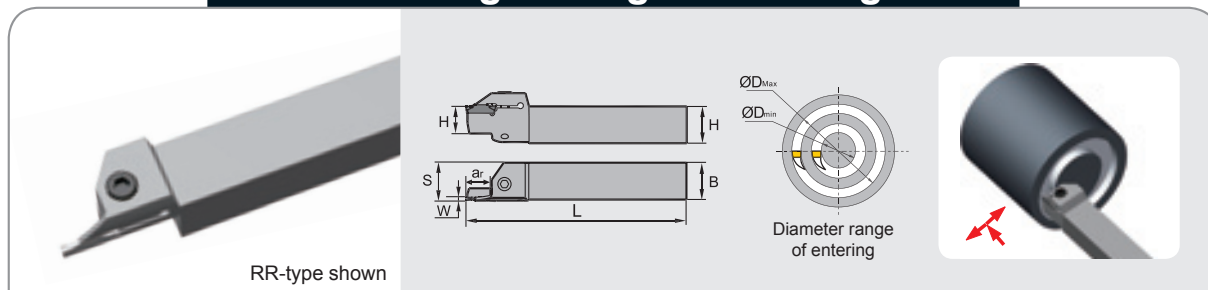

RR-type shown

Type	Stock	Basic dimensions(mm)							Applicable inserts	Screw	Wrench
		H×B	L	S	W	ar max	ØD (min-max)				
<b>QFHD</b>	<b>2525RR13-58H</b>	△	25×25	150	26	5	13	58-96	ZTHD0504-□□	GB70-85-M6×20	WH50L
	<b>2525RR22-58H</b>	△	25×25	150	26	5	22	58-96			
	<b>2525RR13-86H</b>	△	25×25	150	26	5	13	86-140			
	<b>2525RR22-86H</b>	△	25×25	150	26	5	22	86-140			
	<b>2525RR13-130H</b>	△	25×25	150	26	5	13	130-200			
	<b>2525RR22-130H</b>	△	25×25	150	26	5	22	130-200			
	<b>2525RR13-185H</b>	△	25×25	150	26	5	13	185-400			
	<b>2525RR22-185H</b>	△	25×25	150	26	5	22	185-400			
<b>QFHS</b>	<b>2525RR30-185H</b>	△	25×25	150	26	5	30	185-400	ZTHS0504-MG		
<b>QFKD</b>	<b>2525RR13-60H</b>	△	25×25	150	26	6	13	60-100	ZTKD0608-□□	GB70-85-M6×20	WH50L
	<b>2525RR22-60H</b>	△	25×25	150	26	6	22	60-100			
	<b>2525RR13-88H</b>	△	25×25	150	26	6	13	88-180			
	<b>2525RR22-88H</b>	△	25×25	150	26	6	22	88-180			
	<b>2525RR13-160H</b>	△	25×25	150	26	6	13	160-400			
	<b>2525RR22-160H</b>	△	25×25	150	26	6	22	160-400			
<b>QFKS</b>	<b>2525RR30-160H</b>	△	25×25	150	26	6	30	160-400	ZTKS0608-MG		

▲Stock available

△Make-to-order

General turning

Parting and grooving

Little squirrel series parting and grooving tools



# TURNING / Parting and grooving tools

Little squirrel series parting and grooving tools

## End surface grooving and turning tools



LL-type shown

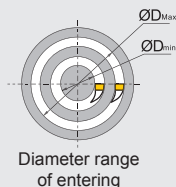
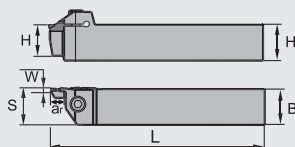

Diameter range of entering



General turning

Parting and grooving

Little squirrel series parting and grooving tools

Type	Stock	Basic dimensions(mm)							Applicable inserts	Screw	Wrench
		H×B	L	S	W	ar max	ØD (min-max)				
<b>QFFD</b>	2020LL7-48H	△	20×20	150	21	3	7	48-66	ZTFD0303-□□	GB70-85-M6×20	WH50L
	2020LL10-48H	△	20×20	150	21	3	10	48-66			
	2525LL10-48H	△	25×25	150	26	3	10	48-66			
	2525LL17-48H	△	25×25	150	26	3	17	48-66			
	2020LL7-60H	△	20×20	150	21	3	7	60-80			
	2020LL10-60H	△	20×20	150	21	3	10	60-80			
	2525LL10-60H	△	25×25	150	26	3	10	60-80			
	2525LL17-60H	△	25×25	150	26	3	17	60-80			
	2020LL7-74H	△	20×20	150	21	3	7	74-110			
	2020LL10-74H	△	20×20	150	21	3	10	74-110			
	2525LL10-74H	△	25×25	150	26	3	10	74-110			
	2525LL17-74H	△	25×25	150	26	3	17	74-110			
	2020LL7-100H	△	20×20	150	21	3	7	100-150			
	2020LL10-100H	△	20×20	150	21	3	10	100-150			
2525LL10-100H	△	25×25	150	26	3	10	100-150				
2525LL17-100H	△	25×25	150	26	3	17	100-150				
<b>QFGD</b>	2020LL10-52H	△	20×20	150	21	4	10	52-72	ZTGD0404-□□	GB70-85-M6×20	WH50L
	2020LL15-52H	△	20×20	150	26	4	15	52-72			
	2525LL13-52H	△	25×25	150	21	4	13	52-72			
	2525LL22-52H	△	25×25	150	26	4	22	52-72			
	2020LL10-64H	△	20×20	150	21	4	10	64-100			
	2020LL15-64H	△	20×20	150	26	4	15	64-100			
	2525LL13-64H	△	25×25	150	21	4	13	64-100			
	2525LL22-64H	△	25×25	150	26	4	22	64-100			
	2020LL10-90H	△	20×20	150	21	4	10	90-140			
	2020LL15-90H	△	20×20	150	26	4	15	90-140			
	2525LL13-90H	△	25×25	150	21	4	13	90-140			
	2525LL22-90H	△	25×25	150	26	4	22	90-140			
	2020LL10-130H	△	20×20	150	21	4	10	130-230			
	2020LL15-130H	△	20×20	150	26	4	15	130-230			
2525LL13-130H	△	25×25	150	21	4	13	130-230				
2525LL22-130H	△	25×25	150	26	4	22	130-230				

▲Stock available    △Make-to-order





## End surface grooving and turning tools



LL-type shown

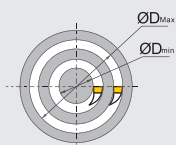
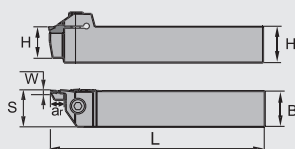

Diameter range of entering



Type	Stock	Basic dimensions(mm)							Applicable inserts	Screw	Wrench
		H×B	L	S	W	a <sub>r</sub> max	∅D (min-max)				
<b>QFHD</b>	<b>2525LL13-58H</b>	△	25×25	150	26	5	13	58-96	ZTHD0504-□□	GB70-85-M6×20	WH50L
	<b>2525LL22-58H</b>	△	25×25	150	26	5	22	58-96			
	<b>2525LL13-86H</b>	△	25×25	150	26	5	13	86-140			
	<b>2525LL22-86H</b>	△	25×25	150	26	5	22	86-140			
	<b>2525LL13-130H</b>	△	25×25	150	26	5	13	130-200			
	<b>2525LL22-130H</b>	△	25×25	150	26	5	22	130-200			
	<b>2525LL13-185H</b>	△	25×25	150	26	5	13	185-400			
	<b>2525LL22-185H</b>	△	25×25	150	26	5	22	185-400			
<b>QFHS</b>	<b>2525LL30-185H</b>	△	25×25	150	26	5	30	185-400	ZTHS0504-MG		
<b>QFKD</b>	<b>2525LL13-60H</b>	△	25×25	150	26	6	13	60-100	ZTKD0608-□□	GB70-85-M6×20	WH50L
	<b>2525LL22-60H</b>	△	25×25	150	26	6	22	60-100			
	<b>2525LL13-88H</b>	△	25×25	150	26	6	13	88-180			
	<b>2525LL22-88H</b>	△	25×25	150	26	6	22	88-180			
	<b>2525LL13-160H</b>	△	25×25	150	26	6	13	160-400			
	<b>2525LL22-160H</b>	△	25×25	150	26	6	22	160-400			
<b>QFKS</b>	<b>2525LL30-160H</b>	△	25×25	150	26	6	30	160-400	ZTKS0608-MG		

▲Stock available

△Make-to-order

General turning

Parting and grooving

Little squirrel series parting and grooving tools



# TURNING / Parting and grooving tools

Little squirrel series parting and grooving tools

## L type tools for surface grooving and turning

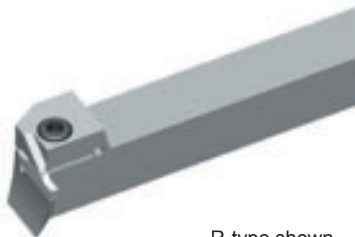

R-type shown

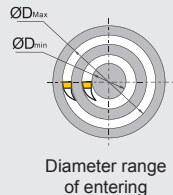
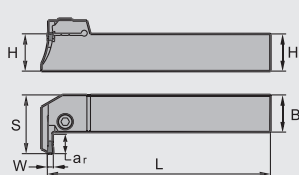

Diameter range of entering



General turning

Parting and grooving

Little squirrel series parting and grooving tools



Type	Stock		Basic dimensions(mm)							Applicable inserts	Screw	Wrench
	R	L	H×B	L	S	W	ar max	ØD (min-max)				
<b>QFFD</b>	2020R/L7-48L	△	△	20×20	150	28.5	3	7	48-66	ZTFD0303-□□	GB70-85-M6×20	WH50L
	2020R/L10-48L	△	△	20×20	150	31.5	3	10	48-66			
	2525R/L10-48L	▲	▲	25×25	150	36.5	3	10	48-66			
	2525R/L17-48L	△	△	25×25	150	43.5	3	17	48-66			
	2020R/L7-60L	△	△	20×20	150	28.5	3	7	60-80			
	2020R/L10-60L	△	△	20×20	150	31.5	3	10	60-80			
	2525R/L10-60L	▲	▲	25×25	150	36.5	3	10	60-80			
	2525R/L17-60L	△	△	25×25	150	43.5	3	17	60-80			
	2020R/L7-74L	△	△	20×20	150	28.5	3	7	74-110			
	2020R/L10-74L	△	△	20×20	150	31.5	3	10	74-110			
	2525R/L10-74L	▲	▲	25×25	150	36.5	3	10	74-110			
	2525R/L17-74L	△	△	25×25	150	43.5	3	17	74-110			
	2020R/L7-100L	△	△	20×20	150	28.5	3	7	100-150			
	2020R/L10-100L	△	△	20×20	150	31.5	3	10	100-150			
	2525R/L10-100L	▲	▲	25×25	150	36.5	3	10	100-150			
2525R/L17-100L	△	△	25×25	150	43.5	3	17	100-150				
<b>QFGD</b>	2020R/L10-52L	△	△	20×20	150	31.5	4	10	52-72	ZTGD0404-□□	GB70-85-M6×20	WH50L
	2525R/L13-52L	▲	△	25×25	150	39.5	4	13	52-72			
	2020R/L15-52L	△	△	20×20	150	36.5	4	15	52-72			
	2525R/L22-52L	△	△	25×25	150	48.5	4	22	52-72			
	2020R/L10-64L	△	△	20×20	150	31.5	4	10	64-100			
	2525R/L13-64L	△	△	25×25	150	39.5	4	13	64-100			
	2020R/L15-64L	△	△	20×20	150	36.5	4	15	64-100			
	2525R/L22-64L	△	△	25×25	150	48.5	4	22	64-100			
	2020R/L10-90L	△	△	20×20	150	31.5	4	10	90-140			
	2525R/L13-90L	△	△	25×25	150	39.5	4	13	90-140			
	2020R/L15-90L	△	△	20×20	150	36.5	4	15	90-140			
	2525R/L22-90L	▲	△	25×25	150	48.5	4	22	90-140			
	2020R/L10-130L	△	△	20×20	150	31.5	4	10	130-230			
	2525R/L13-130L	△	△	25×25	150	39.5	4	13	130-230			
	2020R/L15-130L	△	△	20×20	150	36.5	4	15	130-230			
2525R/L22-130L	▲	▲	25×25	150	48.5	4	22	130-230				

▲ Stock available    △ Make-to-order

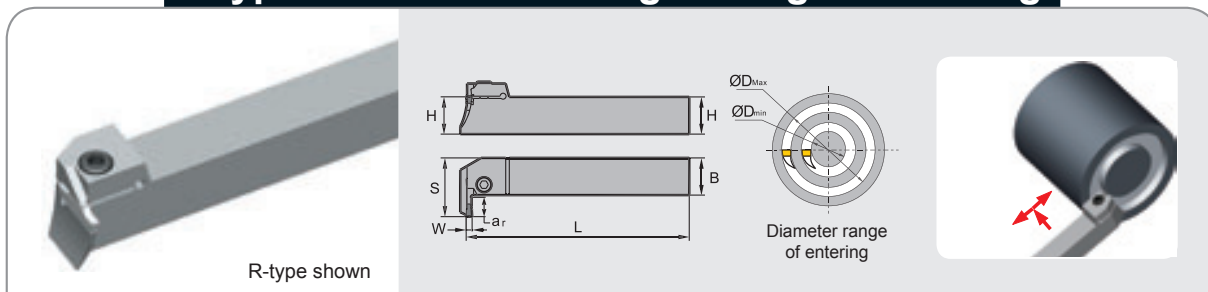

### L type tools for surface grooving and turning



Type	Stock		Basic dimensions(mm)							Applicable inserts	Screw	Wrench
	R	L	H×B	L	S	W	ar max	ØD (min-max)				
<b>QFHD</b>	<b>2525R/L13-58L</b>	△	△	25×25	150	39.5	5	13	58-96	ZTHD0504-□□	GB70-85-M6×20	WH50L
	<b>2525R/L22-58L</b>	△	△	25×25	150	48.5	5	22	58-96			
	<b>2525R/L13-86L</b>	△	△	25×25	150	39.5	5	13	86-140			
	<b>2525R/L22-86L</b>	△	△	25×25	150	48.5	5	22	86-140			
	<b>2525R/L13-130L</b>	△	△	25×25	150	39.5	5	13	130-200			
	<b>2525R/L22-130L</b>	△	△	25×25	150	48.5	5	22	130-200			
	<b>2525R/L13-185L</b>	△	△	25×25	150	39.5	5	13	185-400			
	<b>2525R/L22-185L</b>	▲	△	25×25	150	48.5	5	22	185-400			
<b>QFHS</b>	<b>2525R/L30-185L</b>	△	△	25×25	150	56.5	5	30	185-400	ZTHS0504-MG		
<b>QFKD</b>	<b>2525R/L13-60L</b>	▲	▲	25×25	150	39.5	6	13	60-100	ZTKD0608-□□	GB70-85-M6×20	WH50L
	<b>2525R/L22-60L</b>	▲	▲	25×25	150	48.5	6	22	60-100			
	<b>2525R/L13-88L</b>	△	▲	25×25	150	39.5	6	13	88-180			
	<b>2525R/L22-88L</b>	▲	▲	25×25	150	48.5	6	22	88-180			

▲ Stock available    △ Make-to-order

General turning

Parting and grooving

Little squirrel series parting and grooving tools

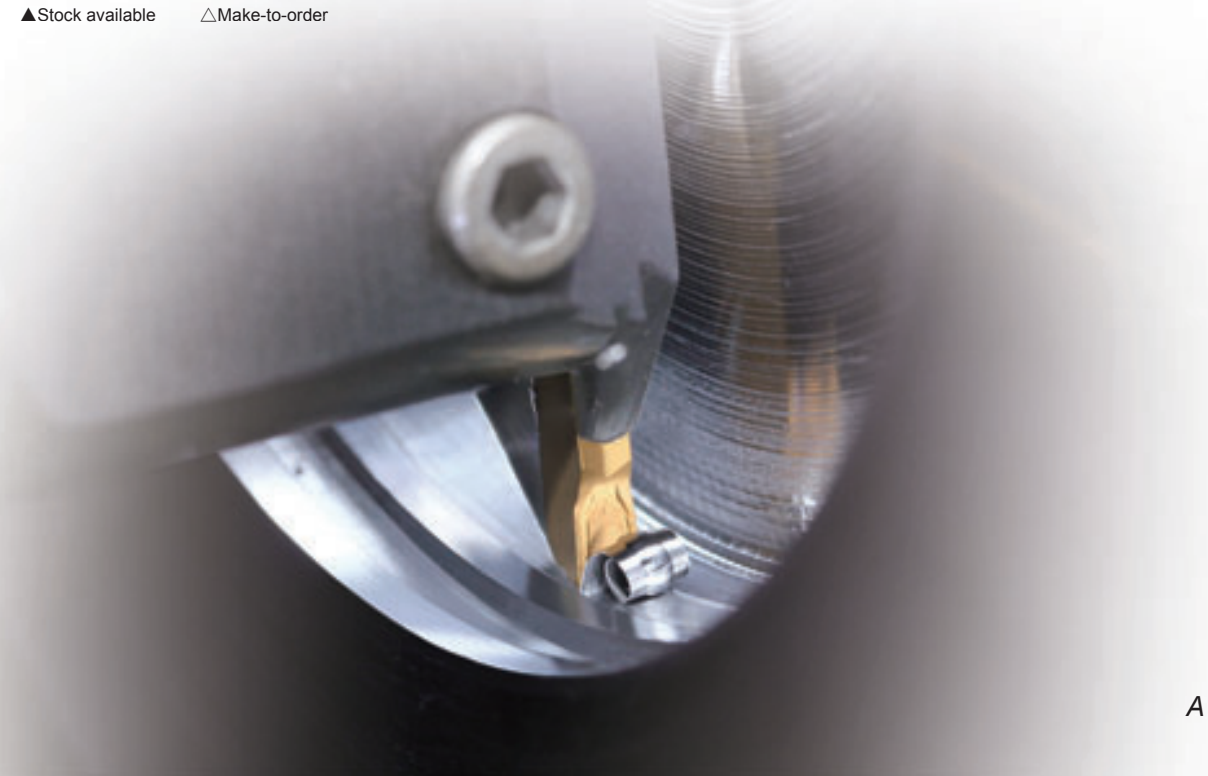



# TURNING Parting and grooving tools

Little squirrel series parting and grooving tools

## Internal grooving and turning tools

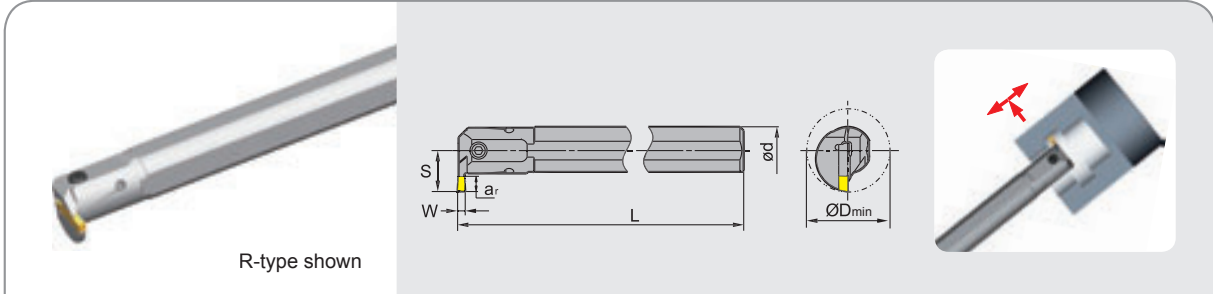

R-type shown

Type	Stock		Basic dimensions(mm)						Applicable inserts	Screw	Wrench
	R	L	ød	L	S	W	ar <sub>max</sub>	ØD <sub>min</sub>			
C20Q-QEDR/L05-27	▲	▲	20	180	15.2	2.5	5	27	ZTED025□□ ZRED025□□	GB70-85-M4×12	WH30L
C25R-QEDR/L07-33	▲	▲	25	200	20.3	2.5	7	33		GB70-85-M5×16	WH40L
C32S-QEDR/L09-42	▲	▲	32	250	25.3	2.5	9	42	ZTFD03□□ ZRFD03□□	GB70-85-M5×20	WH40L
C20Q-QFDR/L05-27	▲	▲	20	180	15.2	3	5	27		GB70-85-M4×12	WH30L
C25R-QFDR/L07-33	▲	▲	25	200	20.3	3	7	33	ZTGD04□□ ZRGD04□□	GB70-85-M5×16	WH40L
C32S-QFDR/L09-42	▲	▲	32	250	25.3	3	9	42		GB70-85-M5×20	WH40L
C25R-QGDR/L08-35	▲	▲	25	200	21.5	4	8	35	ZTHD05□□ ZRHD05□□	GB70-85-M5×16	WH40L
C32S-QGDR/L11-44	▲	▲	32	250	27.5	4	11	44		GB70-85-M6×20	WH50L
C40T-QGDR/L13-54	▲	▲	40	300	33.5	4	13	54	ZTKD06□□ ZRKD06□□	GB70-85-M6×20	WH50L
C25R-QHDR/L08-35	▲	▲	25	200	21.5	5	8	35		GB70-85-M5×16	WH40L
C32S-QHDR/L11-44	▲	▲	32	250	27.5	5	11	44	ZTKD06□□ ZRKD06□□	GB70-85-M6×20	WH50L
C40T-QHDR/L13-54	▲	▲	40	300	33.5	5	13	54		GB70-85-M6×20	WH50L
C25R-QKDR/L08-35	▲	▲	25	200	21.5	6	8	35	ZTKD06□□ ZRKD06□□	GB70-85-M5×16	WH40L
C32S-QKDR/L11-44	▲	▲	32	250	27.5	6	11	44		GB70-85-M6×20	WH50L
C40T-QKDR/L13-54	▲	▲	40	300	33.5	6	13	54	ZTKD06□□ ZRKD06□□	GB70-85-M6×20	WH50L

▲Stock available    △Make-to-order

## Profile turning tools for Al

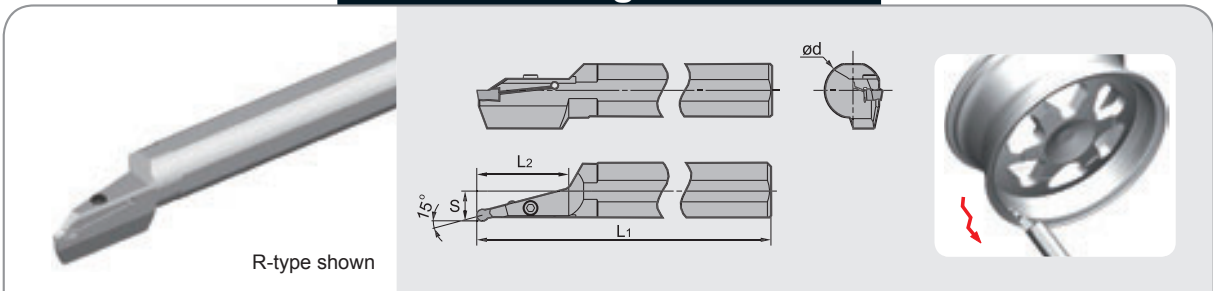

R-type shown

Type	Stock		Basic dimensions(mm)					Applicable inserts	Screw	Wrench
	R	L	ØD (Minimum machining diameter)	ød	S	L1	L2			
C40X-QLDR/L65-15A	▲	▲	160	40	21	320	65	ZRLD08-LH	GB70-85-M6×20	WH50L
C40X-QLDR/L80-15A	▲	△	160	40	21	320	80	ZRLD08-LH		
C40X-QKDR/L60-15A	△	△	160	40	20	320	60	ZRKD06-LH		
C40X-QKDR/L75-15A	△	△	160	40	20	320	75	ZRKD06-LH		

▲Stock available    △Make-to-order

General turning

Parting and grooving

Little squirrel series parting and grooving tools



**QC series** shallow grooving tools code key

● External shallow groove tools

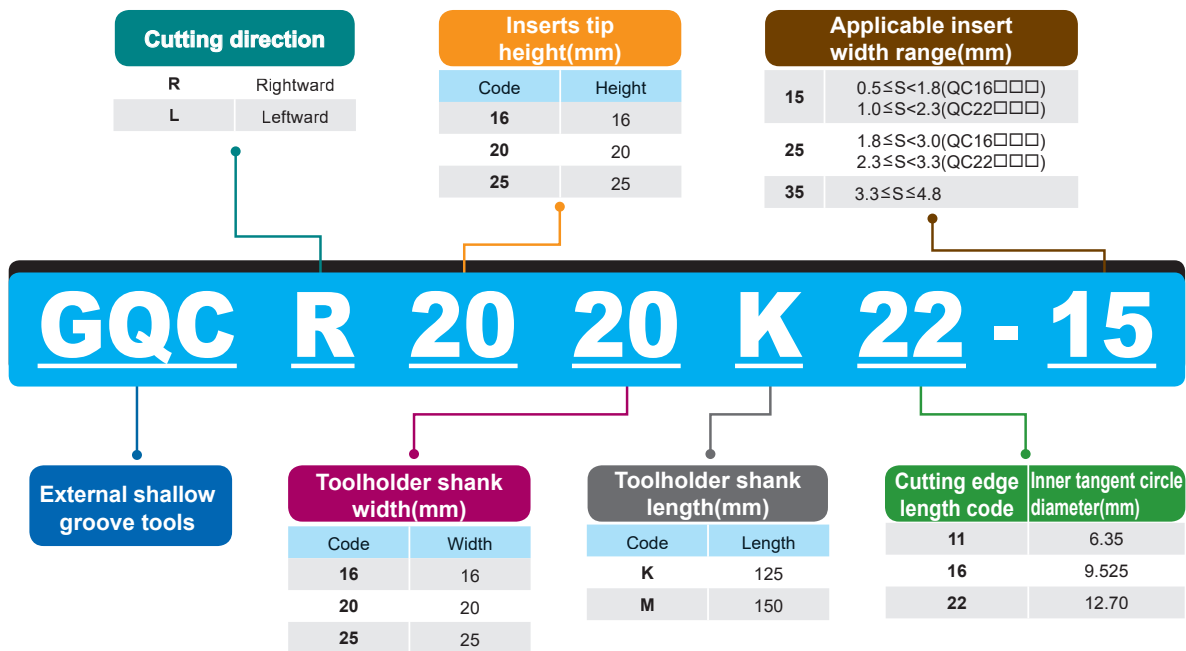

General turning

Parting and grooving

QC series shallow grooving tools

● Internal shallow groove tools

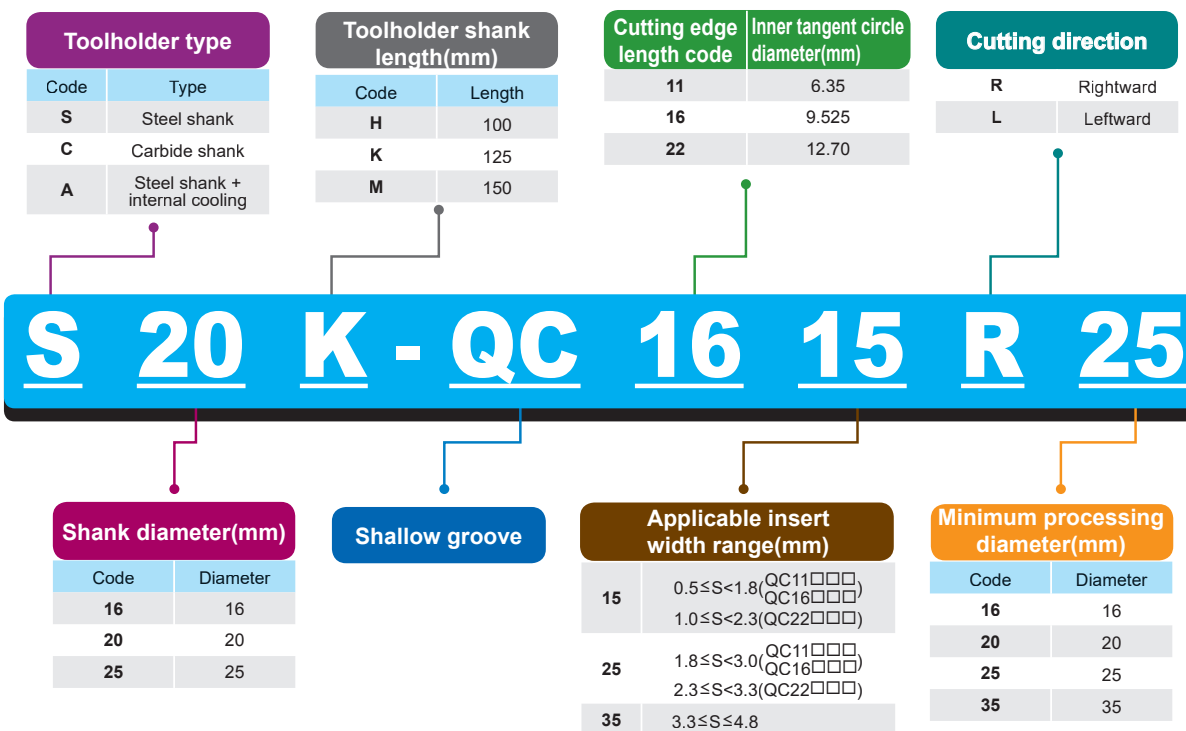



# TURNING / Parting and grooving tools

## QC series shallow grooving tools

### External shallow groove tools

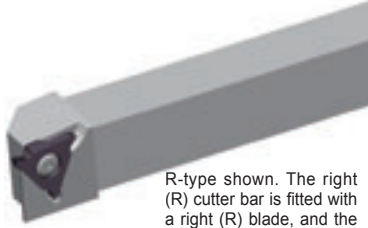

R-type shown. The right (R) cutter bar is fitted with a right (R) blade, and the left (L) cutter bar is fitted with a left (L) blade.

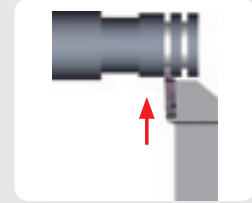
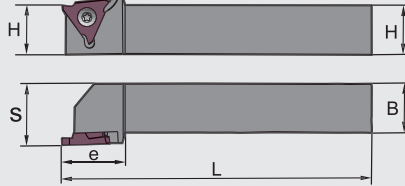

Type	Stock	Basic dimensions(mm)					Width (mm)	Applicable inserts	Screw	Wrench
		H	B	S	e	L				
<b>GQCR/L</b>	<b>1616K16-15</b>	▲	16	16	21	25.5	125	QC16R/L 110~180	I60M3.5×10	WT15IP
	<b>2020K16-15</b>	▲	20	20	25		125			
	<b>2525M16-15</b>	▲	25	25	30		150			
	<b>1616K16-25</b>	▲	16	16	21		125			
	<b>2020K16-25</b>	▲	20	20	25		125			
	<b>2525M16-25</b>	▲	25	25	30		150			
	<b>2020K22-15</b>	▲	20	20	25		125	QC22R/L 100~230	I60M5×13	WT20IP
	<b>2525M22-15</b>	▲	25	25	30		150			
	<b>2020K22-25</b>	▲	20	20	25		125			
	<b>2525M22-25</b>	▲	25	25	30		150	QC22R/L 230~330	I60M5×13	WT20IP
	<b>2020K22-35</b>	▲	20	20	25		125			
	<b>2525M22-35</b>	▲	25	25	30		150	QC22R/L 330~480		

▲Stock available    △Make-to-order

### Internal shallow groove tools

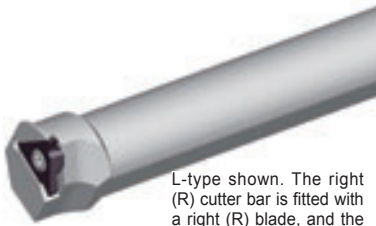

L-type shown. The right (R) cutter bar is fitted with a right (R) blade, and the left (L) cutter bar is fitted with a left (L) blade.

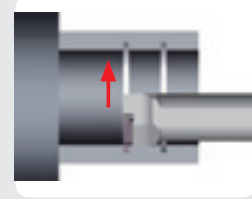
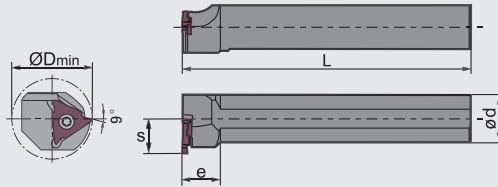

Type	Stock	Basic dimensions(mm)					Width (mm)	Applicable inserts	Screw	Wrench
		ØD <sub>min</sub>	ød	S	e	L				
<b>S20K-QC1115R/L 16</b>	▲	16	20	11.1	40	125	1.2-1.8	QC11R/L 120~180	I60M2.5×6.5	WT07IP
<b>S20K-QC1125R/L 16</b>	▲	16	20	11.1	40	125	1.8-3.0			
<b>S16H-QC1115R/L 20</b>	▲	21	16	11.5	12	100	1.2-1.8	QC11R/L 120~180	I60M3.5×10	WT15IP
<b>S16H-QC1125R/L 20</b>	▲	21	16	11.5	12	100	1.8-3.0	QC11R/L 180~300		
<b>S20M-QC1615R/L 25</b>	▲	26	20	12.5	15	150	1.1-1.8	QC16R/L 110~180	I60M5×13	WT20IP
<b>S20M-QC1625R/L 25</b>	▲			12.5			1.8-3.0	QC16R/L 180~300		
<b>S25M-QC2215R/L 35</b>	▲	35	25	18.2	20	150	1.0-2.3	QC22R/L 100~230	I60M5×13	WT20IP
<b>S25M-QC2225R/L 35</b>	▲			18.2			2.3-3.3	QC22R/L 230~330		
<b>S25M-QC2235R/L 35</b>	▲			18.2			3.3-4.8	QC22R/L 330~480		

▲Stock available    △Make-to-order

General turning

Parting and grooving

QC series shallow grooving tools



Parting and grooving tools code key

● External grooving

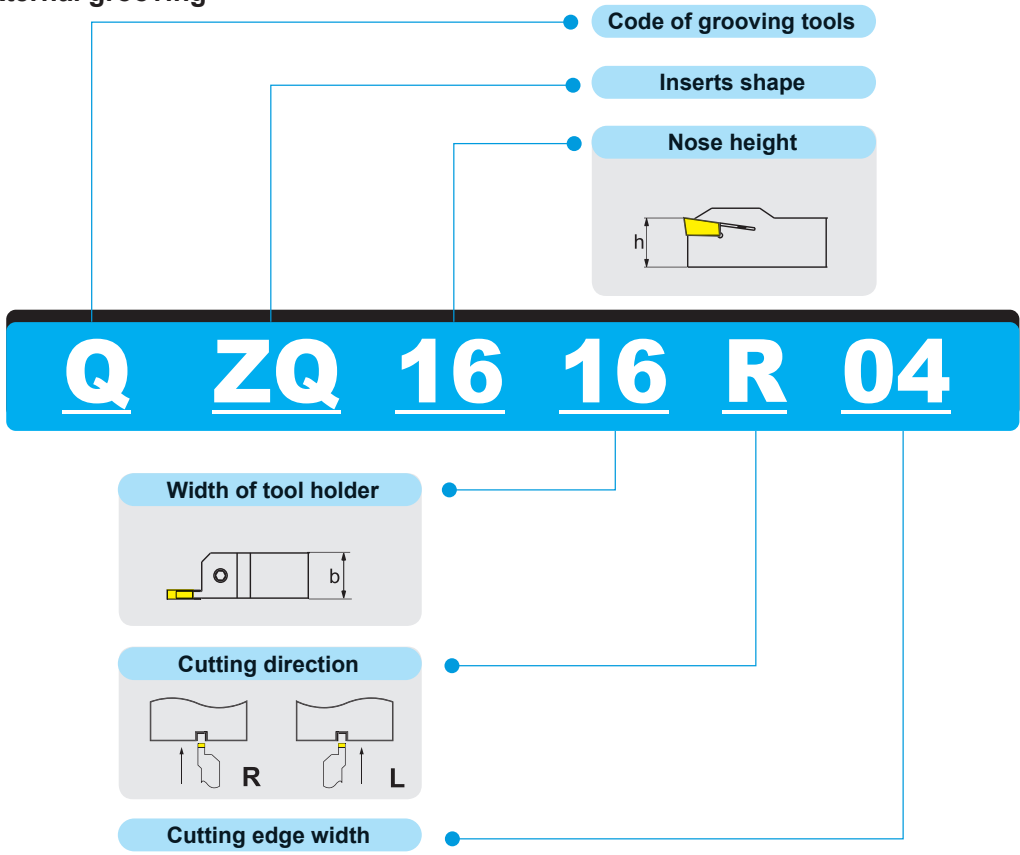

● Internal grooving

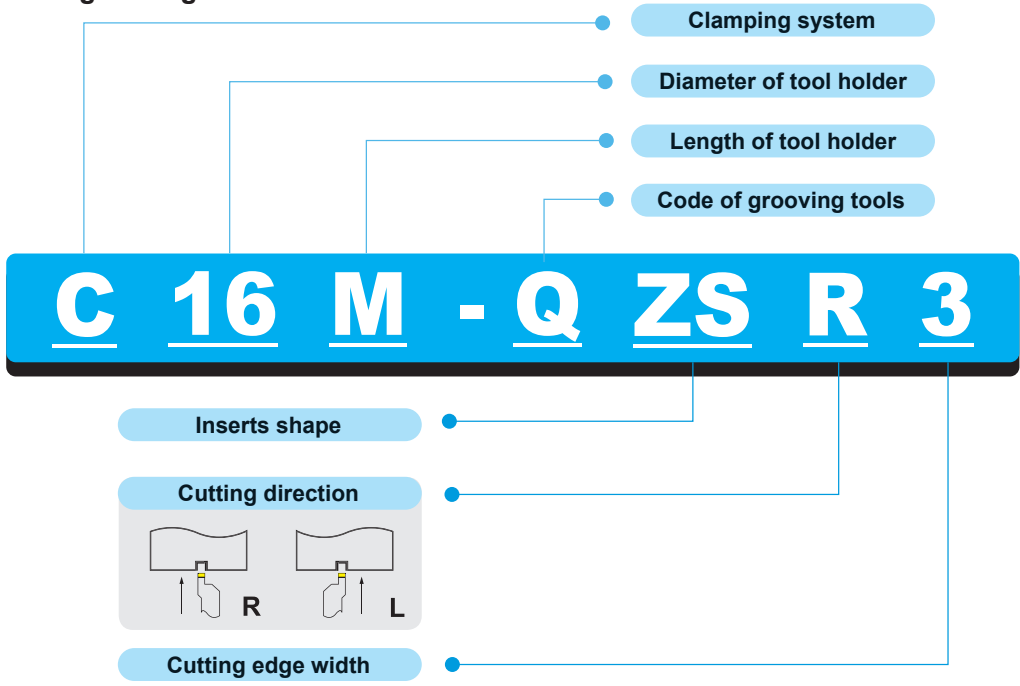

General turning

Parting and grooving

Supplementary series parting and grooving inserts



### External parting and grooving tools: QZQ series



R-type shown

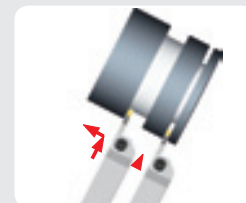
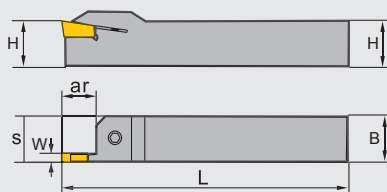

General turning

Parting and grooving

Supplementary series parting and grooving inserts

Type	Stock		Basic dimensions(mm)							Applicable inserts	Screw	Wrench		
	R	L	H	B	L	S	W	ar <sub>max</sub>						
<b>QZQ</b>	1616R/L03	▲	▲	16	16	100	16.4	3	16	ZQMX3N11-IE	GB70-85-M5 × 16	WH40L		
	1616R/L04	▲	▲	16	16	100	16.4	4	18	ZQMX4N11-IE				
	2020R/L03	▲	▲	20	20	125	20.4	3	20	ZQMX3N11-IE			GB70-85-M6 × 20	WH50L
	2020R/L04	▲	▲	20	20	125	20.4	4	20	ZQMX4N11-IE				
	2525R/L03	▲	▲	25	25	150	25.4	3	20	ZQMX3N11-IE				
	2525R/L04	▲	▲	25	25	150	25.4	4	20	ZQMX4N11-IE				
	2525R/L05	▲	▲	25	25	150	25.4	5	25	ZQMX5N11-IE				
	2525R/L06	▲	▲	25	25	150	25.7	6	32	ZQMX6N11-IE				
	3225R/L03	▲	▲	32	25	170	25.4	3	25	ZQMX3N11-IE				
	3225R/L04	▲	▲	32	25	170	25.4	4	25	ZQMX4N11-IE				
	3225R/L05	▲	▲	32	25	170	25.4	5	25	ZQMX5N11-IE				
	3225R/L06	▲	▲	32	25	170	25.7	6	35	ZQMX6N11-IE				

▲ Stock available

△ Make-to-order



### Center height control of parting and grooving tools

- No matter which parting or grooving tools you select, the ideal surface quality is only achieved by ensuring that insert is vertical from the center line of workpiece, which can also effectively reduce vibration during machining.
- The height tolerance between insert edge bottom and the center height of workpiece should be remained in  $\pm 0.1\text{mm}$ , especially for lever parting and grooving workpieces with small diameter. This can improve tool life, reduce cutting resistant force, and diminish burrs.

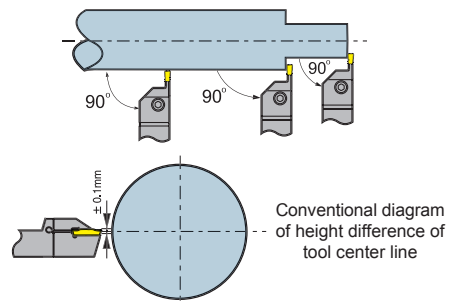

#### Parting

- When the insert is approaching the center of workpiece, the cutting speed should be reduced by 30%, which is good for improving life and surface quality.
- As long as conditions allow, try to shorten the overhang of tools as much as possible to ensure good stability.

#### External grooving, turning and profiling

- In-feed sequence: When cutting depth  $> 0.5\text{mm}$ , radial in-feed (Max. cutting depth can be  $0.75 \times \text{insert edge width } S$ )  $\rightarrow$  radial out-feed about  $0.1\text{mm}$   $\rightarrow$  axial in-feed  $\rightarrow$  flank out-feed  $\rightarrow$  axial in-feed  $\rightarrow$  radial machining to required depth.
- When finishing, adopt the sequence shown in the diagram. It can reduce vibration caused by the friction between tools and chips.

#### Surface grooving and turning

- Finishing (Multi-slot cutting)  
Cut inwards from Max. diameter. Inserts offset to inward flange when retracting, as is shown in diagram (1).
- Recess turning  
Axial turning depth should not exceed  $0.75 \times S$  (cutting edge width).  
If slot width is larger than slot depth, it is recommended to adopt recess turning, as is shown in diagram (2).  
If slot depth is larger than slot depth, it is recommended to adopt multi-slot cutting.
- Finish machining  
First finish bottom and external diameter fringe, then finish the internal diameter to required size, as is shown in diagram (3).

#### Internal grooving and turning

- To facilitate chip flow, always feed along the direction of moving from the deepest in the hole to outside.

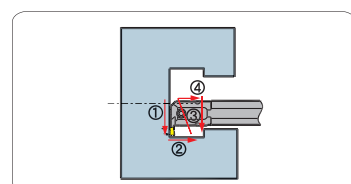
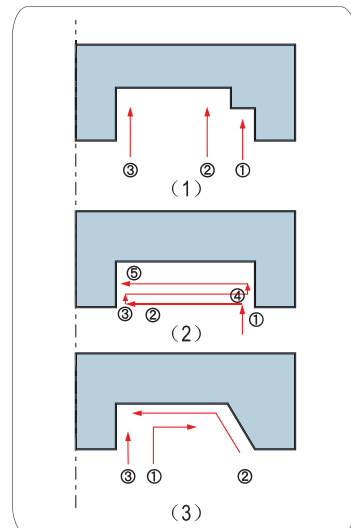
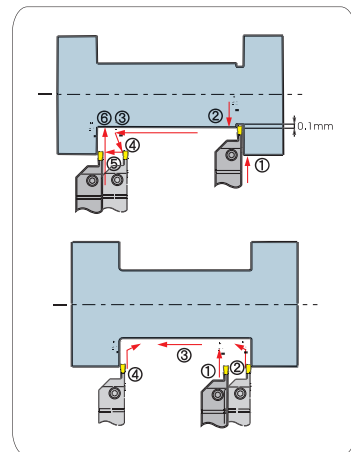



# TURNING / Parting and grooving tools

Application information of parting and grooving

The cutting parameters recommended are suitable for wet machining.

General turning

Parting and grooving

Application information of parting and grooving

Insert size	Recommended feed rate(mm/r)						
	Insert width(mm)	Parting	Grooving	Grooving(-MM)	Turning	Turning(-MM)	Profiling
2.5		0.05-0.15	0.05-0.15	0.05-0.2	0.05-0.15	0.05-0.2	0.05-0.15
3		0.05-0.15	0.05-0.15	0.05-0.2	0.07-0.15	0.07-0.2	0.1-0.2
4		0.05-0.2	0.05-0.2	0.05-0.25	0.07-0.25	0.07-0.3	0.1-0.2
5		0.07-0.2	0.07-0.22	0.07-0.25	0.1-0.25	0.1-0.3	0.15-0.3
6		0.1-0.3	0.07-0.25	0.07-0.3	0.1-0.3	0.1-0.35	0.15-0.3
8				0.1-0.4		0.15-0.45	

Workpiece material	Hardness	Recommended feed rate(mm/r)											
		YBG302	YBG202 YBG205	YBG105	YBG212	YBC151	YBC251	YBS103	YD101	YD201	YBG102	YC10	YC40
<b>P</b> Carbon steel	125 ≤ HB ≤ 170	120-260	150-280			140-280	150-280					130-280	110-260
	Low alloy steel	180 ≤ HB ≤ 275	80-175	110-200		100-240	110-200					90-200	70-175
	High alloy steel	180 ≤ HB ≤ 325	80-160	110-190		100-220	110-190					90-190	70-160
	Cast steel	180 ≤ HB ≤ 250	75-140	100-170		80-160	100-170					80-170	60-140
<b>M</b> Ferrite, Martensite	200 ≤ HB ≤ 300	70-170	100-200				100-200					80-200	60-170
	Austenite	180 ≤ HB ≤ 300	80-200	110-220			110-220					90-220	70-200
<b>K</b> Malleable cast iron	130 ≤ HB ≤ 230	100-200	130-220							90-160			
	Grey cast iron	180 ≤ HB ≤ 220	90-170	120-200						80-140			
	Nodular cast iron	160 ≤ HB ≤ 250	80-150	110-180						60-140			
<b>N</b> Al alloy	--								200-400				
<b>S</b> High temperature alloy	≤ 400			40-70	20-50			30-80	20-50		30-60		

The cutting parameters recommended are suitable for wet machining.

Advice: internal machining and end machining, The cutting speed should be reduced by 30%-40%.

### Recommended cutting parameters for QC series shallow groove tools

Processed material	Recommended insert material (cutting speed m/min)		A: Tool feed for grooving(mm/r)				
	PVD Coating		B: Tool feed for transverse machining(mm/r)				
	YBG202	YBG205	C: Depth of cut for transverse machining(mm)				
			QC**R/L050-120	QC**R/L125-225	QC**R/L230-325	QC**R/L330-400	QC**R/L400-480
Carbon Steel	80-180	80-180	A: 0.03-0.08	A: 0.04-0.09	A: 0.05-0.1	A: 0.05-0.12	A: 0.05-0.12
			Non-horizontal processing	B: 0.04-0.09	B: 0.05-0.1	B: 0.05-0.1	B: 0.05-0.1
			Non-horizontal processing	C: 0.3(MAX)	C: 0.5(MAX)	C: 0.5(MAX)	C: 0.8(MAX)
Alloy Steel	80-160	80-160	A: 0.03-0.07	A: 0.04-0.08	A: 0.05-0.09	A: 0.05-0.1	A: 0.05-0.1
			Non-horizontal processing	B: 0.04-0.08	B: 0.05-0.09	B: 0.05-0.1	B: 0.05-0.1
			Non-horizontal processing	C: 0.3(MAX)	C: 0.5(MAX)	C: 0.5(MAX)	C: 0.5(MAX)
Stainless Steel	60-130	60-130	A: 0.03-0.07	A: 0.04-0.08	A: 0.05-0.09	A: 0.05-0.1	A: 0.05-0.1
			Non-horizontal processing	B: 0.04-0.08	B: 0.05-0.09	B: 0.05-0.1	B: 0.05-0.1
			Non-horizontal processing	C: 0.3(MAX)	C: 0.5(MAX)	C: 0.5(MAX)	C: 0.5(MAX)

The cutting parameters above are applicable to external grooving. When machining internal hole grooves, please reduce the cutting speed and feed by 10%.